

## 混合信号微控制器

### 特性

- 低电源电压范围: **1.8V 至 3.6V**
- 超低功耗
  - 激活模式: **220µA** (在 **1MHz** 频率和 **2.2V** 电压条件下)
  - 待机模式: **0.5µA**
  - 关闭模式 (RAM 保持): **0.1µA**
- **5** 种节能模式
- 可在不到 **1µs** 的时间里超快速地从待机模式唤醒
- **16** 位精简指令集 (RISC) 架构, **62.5ns** 指令周期时间
- 基本时钟模块配置
  - 带有四个已校准频率的高达 **16MHz** 的内部频率
  - 内部超低功耗低频 (LF) 振荡器
  - **32kHz** 晶振
  - 外部数字时钟源
- 一个具有 **3** 个捕获/比较寄存器的 **16** 位 **Timer\_A**
- 多达 **16** 个触感使能输入输出 (I/O) 引脚
- 支持 **SPI** 和 **I2C** 的通用串行接口 (USI)
- 欠压检测器
- 串行板上编程, 无需外部编程电压,

利用安全熔丝实现可编程代码保护

- 具有两线制 (**Spy-Bi-Wire**) 接口的片上仿真逻辑电路
- 系列产品汇总于 **Table 1**
- 封装选项
  - 薄型小外形尺寸封装 (TSSOP): **14** 引脚
- 如需了解完整的模块说明, 请查阅《**MSP430x2xx** 系列产品用户指南》(SLAU144)

支持国防、航空航天、和医疗应用

- 受控基线
- 同一组装和测试场所
- 同一制造场所
- 在扩展 (**-40°C 至 85°C**) 温度范围内可用 <sup>(1)</sup>
- 延长的产品生命周期
- 延长的产品变更通知
- 产品可追溯性

(1) 可定制工作温度范围

### 说明

德州仪器 (TI) 的 MSP430™ 系列超低功率微控制器包含几个器件, 这些器件特有针对多种应用的不同外设集。这种架构与 5 种低功耗模式相组合, 专为在便携式测量应用中延长电池的使用寿命而进行了优化。该器件具有一个强大的 16 位 RISC CPU, 16 位寄存器和有助于大大提高编码效率的常数发生器。数控振荡器可在少于 1 µs 内将器件从低功耗模式唤醒至激活模式。

MSP430G2302 系列微控制器是超低功耗混合信号微控制器, 此微控制器带有内置的 16 位定时器, 和多达 16 个 I/O 触感使能引脚以及使用通用串行通信接口实现的内置通信功能。

配置详细信息, 请参见 **Table 1**。典型应用包括低成本传感器系统, 此类系统负责捕获模拟信号、将之转换为数字值、随后对数据进行处理以进行显示或传送至主机系统。



Please be aware that an important notice concerning availability, standard warranty, and use in critical applications of Texas Instruments semiconductor products and disclaimers thereto appears at the end of this data sheet.

MSP430 is a trademark of Texas Instruments.

All other trademarks are the property of their respective owners.

**Table 1. Available Options<sup>(1)</sup>**

Device	EEM	Flash (kB)	RAM (B)	Timer_A	ADC10 Channel	USI	CLOCK	I/O	Package Type
MSP430G2302IPW1REP	1	4	256	1x TA3	-	1	LF, DCO, VLO	10	14-TSSOP

(1) For the most current package and ordering information, see the Package Option Addendum at the end of this document, or see the TI web site at [www.ti.com](http://www.ti.com).

**Table 2. ORDERING INFORMATION<sup>(1)</sup>**

T <sub>A</sub>	PACKAGE	ORDERABLE PART NUMBER	TOP-SIDE MARKING	VID NUMBER
-40°C to 85°C	TSSOP - PW	MSP430G2302IPW1EP	G2302EP	V62/12623-01XE
		MSP430G2302IPW1REP		

(1) For the most current package and ordering information, see the Package Option Addendum at the end of this document, or see the TI Web site at [www.ti.com](http://www.ti.com).



This integrated circuit can be damaged by ESD. Texas Instruments recommends that all integrated circuits be handled with appropriate precautions. Failure to observe proper handling and installation procedures can cause damage.

ESD damage can range from subtle performance degradation to complete device failure. Precision integrated circuits may be more susceptible to damage because very small parametric changes could cause the device not to meet its published specifications.

## DEVICE PINOUTS

### PW PACKAGE (TOP VIEW)

DVCC	1	14	DVSS
P1.0/TA0CLK/ACLK/A0	2	13	XIN/P2.6/TA0.1
P1.1/TA0.0/A1	3	12	XOUT/P2.7
P1.2/TA0.1/A2	4	11	TEST/SBWTCK
P1.3/ADC10CLK/A3/VREF-/VEREF-	5	10	RST/NMI/SBWTIO
P1.4/TA0.2/SMCLK/A4/VREF+/VEREF+/TCK	6	9	P1.7/SDI/SDA/A7/TDO/TDI
P1.5/TA0.0/SCLK/A5/TMS	7	8	P1.6/TA0.1/SDO/SCL/A6/TDI/TCLK

NOTE: The pull-down resistors of port pins P2.0, P2.1, P2.2, P2.3, P2.4, and P2.5 should be enabled by setting P2REN.x = 1.

**FUNCTIONAL BLOCK DIAGRAMS**

**Functional Block Diagram, MSP430G2302**

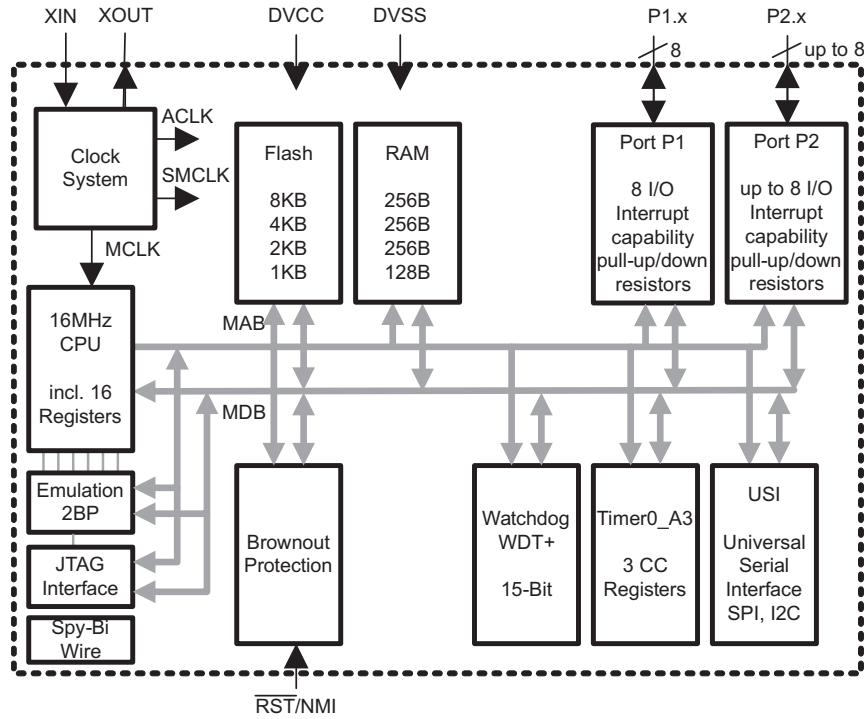

NOTE: Port P2: Two pins are available on the 14-pin package option. Eight pins are available on the 20-pin package option.

## TERMINAL FUNCTIONS

**Table 3. Terminal Functions**

TERMINAL		I/O	DESCRIPTION
NAME	NO. PW14		
P1.0/ TA0CLK/ ACLK/ A0	2	I/O	General-purpose digital I/O pin Timer0_A, clock signal TACLK input ACLK signal output ADC10 analog input A0
P1.1/ TA0.0/ A1	3	I/O	General-purpose digital I/O pin Timer0_A, capture: CCI0A input, compare: Out0 output ADC10 analog input A1
P1.2/ TA0.1/ A2	4	I/O	General-purpose digital I/O pin Timer0_A, capture: CCI1A input, compare: Out1 output ADC10 analog input A2
P1.3/ ADC10CLK/ A3/ VREF-/VEREF	5	I/O	General-purpose digital I/O pin ADC10, conversion clock output ADC10 analog input A3 ADC10 negative reference voltage
P1.4/ TA0.2/ SMCLK/ A4/ VREF+/VEREF+/ TCK	6	I/O	General-purpose digital I/O pin Timer0_A, capture: CCI2A input, compare: Out2 output SMCLK signal output ADC10 analog input A4 ADC10 positive reference voltage JTAG test clock, input terminal for device programming and test
P1.5/ TA0.0/ A5/ SCLK/ TMS	7	I/O	General-purpose digital I/O pin Timer0_A, compare: Out0 output ADC10 analog input A5 USI: clk input in I2C mode; clk in/output in SPI mode JTAG test mode select, input terminal for device programming and test
P1.6/ TA0.1/ A6/ SDO/ SCL/ TDI/ TCLK	8	I/O	General-purpose digital I/O pin Timer0_A, compare: Out1 output ADC10 analog input A6 USI: Data output in SPI mode USI: I2C clock in I2C mode JTAG test data input or test clock input during programming and test
P1.7/ A7/ SDI/ SDA/ TDO/TDI <sup>(1)</sup>	9	I/O	General-purpose digital I/O pin ADC10 analog input A7 USI: Data input in SPI mode USI: I2C data in I2C mode JTAG test data output terminal or test data input during programming and test
XIN/ P2.6/ TA0.1	13	I/O	Input terminal of crystal oscillator General-purpose digital I/O pin Timer0_A, compare: Out1 output

(1) TDO or TDI is selected via JTAG instruction.

**Table 3. Terminal Functions (continued)**

TERMINAL		I/O	DESCRIPTION
NAME	NO. PW14		
XOUT/ P2.7	12	I/O	Output terminal of crystal oscillator <sup>(2)</sup> General-purpose digital I/O pin
$\overline{\text{RST}}$ / NMI/ SBWTDIO/	10	I	Reset Nonmaskable interrupt input Spy-Bi-Wire test data input/output during programming and test
TEST/ SBWTCK	11	I	Selects test mode for JTAG pins on Port 1. The device protection fuse is connected to TEST. Spy-Bi-Wire test clock input during programming and test
DVCC	1	NA	Supply voltage
AVCC	NA	NA	Supply voltage
DVSS	14	NA	Ground reference
AVSS	NA	NA	Ground reference
NC	-	NA	Not connected
QFN Pad	-	NA	QFN package pad connection to VSS recommended.

(2) If XOUT/P2.7 is used as an input, excess current flows until P2SEL.7 is cleared. This is due to the oscillator output driver connection to this pad after reset.

## SHORT-FORM DESCRIPTION

### CPU

The MSP430™ CPU has a 16-bit RISC architecture that is highly transparent to the application. All operations, other than program-flow instructions, are performed as register operations in conjunction with seven addressing modes for source operand and four addressing modes for destination operand.

The CPU is integrated with 16 registers that provide reduced instruction execution time. The register-to-register operation execution time is one cycle of the CPU clock.

Four of the registers, R0 to R3, are dedicated as program counter, stack pointer, status register, and constant generator, respectively. The remaining registers are general-purpose registers.

Peripherals are connected to the CPU using data, address, and control buses, and can be handled with all instructions.

The instruction set consists of the original 51 instructions with three formats and seven address modes and additional instructions for the expanded address range. Each instruction can operate on word and byte data.

### Instruction Set

The instruction set consists of 51 instructions with three formats and seven address modes. Each instruction can operate on word and byte data. [Table 4](#) shows examples of the three types of instruction formats; [Table 5](#) shows the address modes.

Program Counter	PC/R0
Stack Pointer	SP/R1
Status Register	SR/CG1/R2
Constant Generator	CG2/R3
General-Purpose Register	R4
General-Purpose Register	R5
General-Purpose Register	R6
General-Purpose Register	R7
General-Purpose Register	R8
General-Purpose Register	R9
General-Purpose Register	R10
General-Purpose Register	R11
General-Purpose Register	R12
General-Purpose Register	R13
General-Purpose Register	R14
General-Purpose Register	R15

**Table 4. Instruction Word Formats**

FORMAT	EXAMPLE	OPERATION
Dual operands, source-destination	ADD R4,R5	R4 + R5 → R5
Single operands, destination only	CALL R8	PC → (TOS), R8 → PC
Relative jump, un/conditional	JNE	Jump-on-equal bit = 0

**Table 5. Address Mode Descriptions<sup>(1)</sup>**

ADDRESS MODE	S	D	SYNTAX	EXAMPLE	OPERATION
Register	✓	✓	MOV Rs,Rd	MOV R10,R11	R10 → R11
Indexed	✓	✓	MOV X(Rn),Y(Rm)	MOV 2(R5),6(R6)	M(2+R5) → M(6+R6)
Symbolic (PC relative)	✓	✓	MOV EDE,TONI		M(EDE) → M(TONI)
Absolute	✓	✓	MOV &MEM,&TCDAT		M(MEM) → M(TCDAT)
Indirect	✓		MOV @Rn,Y(Rm)	MOV @R10,Tab(R6)	M(R10) → M(Tab+R6)
Indirect autoincrement	✓		MOV @Rn+,Rm	MOV @R10+,R11	M(R10) → R11 R10 + 2 → R10
Immediate	✓		MOV #X,TONI	MOV #45,TONI	#45 → M(TONI)

(1) S = source, D = destination

## Operating Modes

The MSP430 devices have one active mode and five software selectable low-power modes of operation. An interrupt event can wake up the device from any of the low-power modes, service the request, and restore back to the low-power mode on return from the interrupt program.

The following six operating modes can be configured by software:

- Active mode (AM)
  - All clocks are active
- Low-power mode 0 (LPM0)
  - CPU is disabled
  - ACLK and SMCLK remain active, MCLK is disabled
- Low-power mode 1 (LPM1)
  - CPU is disabled
  - ACLK and SMCLK remain active, MCLK is disabled
  - DCO's dc generator is disabled if DCO not used in active mode
- Low-power mode 2 (LPM2)
  - CPU is disabled
  - MCLK and SMCLK are disabled
  - DCO's dc generator remains enabled
  - ACLK remains active
- Low-power mode 3 (LPM3)
  - CPU is disabled
  - MCLK and SMCLK are disabled
  - DCO's dc generator is disabled
  - ACLK remains active
- Low-power mode 4 (LPM4)
  - CPU is disabled
  - ACLK is disabled
  - MCLK and SMCLK are disabled
  - DCO's dc generator is disabled
  - Crystal oscillator is stopped



## Interrupt Vector Addresses

The interrupt vectors and the power-up starting address are located in the address range 0FFFFh to 0FFC0h. The vector contains the 16-bit address of the appropriate interrupt handler instruction sequence.

If the reset vector (located at address 0FFFEh) contains 0FFFFh (for example, if flash is not programmed) the CPU goes into LPM4 immediately after power-up.

**Table 6. Interrupt Sources, Flags, and Vectors**

INTERRUPT SOURCE	INTERRUPT FLAG	SYSTEM INTERRUPT	WORD ADDRESS	PRIORITY
Power-Up External Reset Watchdog Timer+ Flash key violation PC out-of-range <sup>(1)</sup>	PORIFG RSTIFG WDTIFG KEYV <sup>(2)</sup>	Reset	0FFFEh	31, highest
NMI Oscillator fault Flash memory access violation	NMIIFG OFIFG ACCVIFG <sup>(2)(3)</sup>	(non)-maskable (non)-maskable (non)-maskable	0FFFCCh	30
			0FFFAh	29
			0FFF8h	28
			0FFF6h	27
Watchdog Timer+	WDTIFG	maskable	0FFF4h	26
Timer0_A3	TACCR0 CCIFG <sup>(4)</sup>	maskable	0FFF2h	25
Timer0_A3	TACCR2 TACCR1 CCIFG. TAIFG <sup>(4)</sup>	maskable	0FFF0h	24
			0FFEEh	23
			0FFECCh	22
USI	USIIFG, USISTTIFG <sup>(2)(4)</sup>	maskable	0FFE8h	20
I/O Port P2 (up to eight flags)	P2IFG.0 to P2IFG.7 <sup>(2)(4)</sup>	maskable	0FFE6h	19
I/O Port P1 (up to eight flags)	P1IFG.0 to P1IFG.7 <sup>(2)(4)</sup>	maskable	0FFE4h	18
			0FFE2h	17
			0FFE0h	16
See <sup>(5)</sup>			0FFDEh to 0FFC0h	15 to 0, lowest





- (1) A reset is generated if the CPU tries to fetch instructions from within the module register memory address range (0h to 01FFh) or from within unused address ranges.
- (2) Multiple source flags
- (3) (non)-maskable: the individual interrupt-enable bit can disable an interrupt event, but the general interrupt enable cannot.
- (4) Interrupt flags are located in the module.
- (5) The interrupt vectors at addresses 0FFDEh to 0FFC0h are not used in this device and can be used for regular program code if necessary.

## Special Function Registers (SFRs)









Most interrupt and module enable bits are collected into the lowest address space. Special function register bits not allocated to a functional purpose are not physically present in the device. Simple software access is provided with this arrangement.

<b>Legend</b>	<b>rw:</b>	Bit can be read and written.
	<b>rw-0,1:</b>	Bit can be read and written. It is reset or set by PUC.
	<b>rw-(0,1):</b>	Bit can be read and written. It is reset or set by POR.
		SFR bit is not present in device.



**Table 7. Interrupt Enable Register 1 and 2**

Address	7	6	5	4	3	2	1	0
00h			<b>ACCVIE</b>	<b>NMIIE</b>			<b>OFIE</b>	<b>WDTIE</b>
			rw-0	rw-0			rw-0	rw-0









<b>WDTIE</b>	Watchdog Timer interrupt enable. Inactive if watchdog mode is selected. Active if Watchdog Timer is configured in interval timer mode.
<b>OFIE</b>	Oscillator fault interrupt enable
<b>NMIIE</b>	(Non)maskable interrupt enable
<b>ACCVIE</b>	Flash access violation interrupt enable

Address	7	6	5	4	3	2	1	0
01h								

**Table 8. Interrupt Flag Register 1 and 2**

Address	7	6	5	4	3	2	1	0
02h				<b>NMIIFG</b>	<b>RSTIFG</b>	<b>PORIFG</b>	<b>OFIFG</b>	<b>WDTIFG</b>
				rw-0	rw-(0)	rw-(1)	rw-1	rw-(0)

<b>WDTIFG</b>	Set on watchdog timer overflow (in watchdog mode) or security key violation. Reset on $V_{CC}$ power-on or a reset condition at the $\overline{RST}/NMI$ pin in reset mode.
<b>OFIFG</b>	Flag set on oscillator fault.
<b>PORIFG</b>	Power-On Reset interrupt flag. Set on $V_{CC}$ power-up.
<b>RSTIFG</b>	External reset interrupt flag. Set on a reset condition at $\overline{RST}/NMI$ pin in reset mode. Reset on $V_{CC}$ power-up.
<b>NMIIFG</b>	Set via $\overline{RST}/NMI$ pin

Address	7	6	5	4	3	2	1	0
03h								

## Memory Organization

**Table 9. Memory Organization**

		<b>MSP430G2302</b>
Memory	Size	4kB
Main: interrupt vector	Flash	0xFFFF to 0xFFC0
Main: code memory	Flash	0xFFFF to 0xF000
Information memory	Size	256 Byte
	Flash	010FFh to 01000h
RAM	Size	256 B
		0x02FF to 0x0200
Peripherals	16-bit	01FFh to 0100h
	8-bit	0FFh to 010h
	8-bit SFR	0Fh to 00h

### Flash Memory

The flash memory can be programmed via the Spy-Bi-Wire/JTAG port or in-system by the CPU. The CPU can perform single-byte and single-word writes to the flash memory. Features of the flash memory include:

- Flash memory has n segments of main memory and four segments of information memory (A to D) of 64 bytes each. Each segment in main memory is 512 bytes in size.
- Segments 0 to n may be erased in one step, or each segment may be individually erased.
- Segments A to D can be erased individually or as a group with segments 0 to n. Segments A to D are also called *information memory*.
- Segment A contains calibration data. After reset, segment A is protected against programming and erasing. It can be unlocked, but care should be taken not to erase this segment if the device-specific calibration data is required.

## Peripherals

Peripherals are connected to the CPU through data, address, and control buses and can be handled using all instructions. For complete module descriptions, see the *MSP430x2xx Family User's Guide (SLAU144)*.

### Oscillator and System Clock

The clock system is supported by the basic clock module that includes support for a 32768-Hz watch crystal oscillator, an internal very-low-power low-frequency oscillator, and an internal digitally controlled oscillator (DCO). The basic clock module is designed to meet the requirements of both low system cost and low power consumption. The internal DCO provides a fast turn-on clock source and stabilizes in less than 1  $\mu$ s. The basic clock module provides the following clock signals:

- Auxiliary clock (ACLK), sourced either from a 32768-Hz watch crystal or the internal LF oscillator.
- Main clock (MCLK), the system clock used by the CPU.
- Sub-Main clock (SMCLK), the sub-system clock used by the peripheral modules.

The DCO settings to calibrate the DCO output frequency are stored in the information memory segment A.

### Calibration Data Stored in Information Memory Segment A

Calibration data is stored for both the DCO and for ADC10 organized in a tag-length-value structure.

**Table 10. Tags Used by the ADC Calibration Tags**

NAME	ADDRESS	VALUE	DESCRIPTION
TAG_DCO_30	0x10F6	0x01	DCO frequency calibration at $V_{CC} = 3$ V and $T_A = 30^\circ\text{C}$ at calibration
TAG_ADC10_1	0x10DA	0x10	ADC10_1 calibration tag
TAG_EMPTY	-	0xFE	Identifier for empty memory areas

**Table 11. Labels Used by the ADC Calibration Tags**

LABEL	CONDITION AT CALIBRATION / DESCRIPTION	SIZE	ADDRESS OFFSET
CAL_ADC_25T85	INCHx = 0x1010, REF2_5 = 1, $T_A = 85^\circ\text{C}$	word	0x0010
CAL_ADC_25T30	INCHx = 0x1010, REF2_5 = 1, $T_A = 30^\circ\text{C}$	word	0x000E
CAL_ADC_25VREF_FACTOR	REF2_5 = 1, $T_A = 30^\circ\text{C}$ , $I_{(VREF+)} = 1$ mA	word	0x000C
CAL_ADC_15T85	INCHx = 0x1010, REF2_5 = 0, $T_A = 85^\circ\text{C}$	word	0x000A
CAL_ADC_15T30	INCHx = 0x1010, REF2_5 = 0, $T_A = 30^\circ\text{C}$	word	0x0008
CAL_ADC_15VREF_FACTOR	REF2_5 = 0, $T_A = 30^\circ\text{C}$ , $I_{(VREF+)} = 0.5$ mA	word	0x0006
CAL_ADC_OFFSET	External VREF = 1.5 V, $f_{(ADC10CLK)} = 5$ MHz	word	0x0004
CAL_ADC_GAIN_FACTOR	External VREF = 1.5 V, $f_{(ADC10CLK)} = 5$ MHz	word	0x0002
CAL_BC1_1MHz	-	byte	0x0009
CAL_DCO_1MHz	-	byte	0x00008
CAL_BC1_8MHz	-	byte	0x0007
CAL_DCO_8MHz	-	byte	0x0006
CAL_BC1_12MHz	-	byte	0x0005
CAL_DCO_12MHz	-	byte	0x0004
CAL_BC1_16MHz	-	byte	0x0003
CAL_DCO_16MHz	-	byte	0x0002

### Main DCO Characteristics

- All ranges selected by RSELx overlap with RSELx + 1: RSELx = 0 overlaps RSELx = 1, ... RSELx = 14 overlaps RSELx = 15.
- DCO control bits DCOx have a step size as defined by parameter  $S_{DCO}$ .
- Modulation control bits MODx select how often  $f_{DCO(RSEL,DCO+1)}$  is used within the period of 32 DCOCLK cycles. The frequency  $f_{DCO(RSEL,DCO)}$  is used for the remaining cycles. The frequency is an average equal to:

$$f_{\text{average}} = \frac{32 \times f_{DCO(RSEL,DCO)} \times f_{DCO(RSEL,DCO+1)}}{MOD \times f_{DCO(RSEL,DCO)} + (32 - MOD) \times f_{DCO(RSEL,DCO+1)}}$$

### Brownout

The brownout circuit is implemented to provide the proper internal reset signal to the device during power on and power off.

### Digital I/O

There are two 8-bit I/O ports implemented:

- All individual I/O bits are independently programmable.
- Any combination of input, output, and interrupt condition(port P1 and port P2 only) is possible.
- Edge-selectable interrupt input capability for all the eight bits of port P1 and port P2, if available.
- Read/write access to port-control registers is supported by all instructions.
- Each I/O has an individually programmable pullup/pulldown resistor.
- Each I/O has an individually programmable pin-oscillator enable bit to enable low-cost touch sensing.

### WDT+ Watchdog Timer

The primary function of the watchdog timer (WDT+) module is to perform a controlled system restart after a software problem occurs. If the selected time interval expires, a system reset is generated. If the watchdog function is not needed in an application, the module can be disabled or configured as an interval timer and can generate interrupts at selected time intervals.

### Timer0\_A3

Timer0\_A3 is a 16-bit timer/counter with three capture/compare registers. Timer0\_A3 can support multiple capture/compares, PWM outputs, and interval timing. Timer0\_A3 also has extensive interrupt capabilities. Interrupts may be generated from the counter on overflow conditions and from each of the capture/compare registers.

**Table 12. Timer0\_A3 Signal Connections<sup>(1)</sup>**

INPUT PIN NUMBER	DEVICE INPUT SIGNAL	MODULE INPUT NAME	MODULE BLOCK	MODULE OUTPUT SIGNAL	OUTPUT PIN NUMBER
PW14					PW14
P1.0-2	TACLK	TACLK	Timer	NA	
	ACLK	ACLK			
	SMCLK	SMCLK			
PinOsc		INCLK			
P1.1-3	TA0.0	CCI0A	CCR0	TA0	P1.1-3
	ACLK	CCI0B			P1.5-7
	V <sub>SS</sub>	GND			
	V <sub>CC</sub>	V <sub>CC</sub>			
P1.2-4	TA0.1	CCI1A	CCR1	TA1	P1.2-4
	CAOUT	CCI1B			P1.6-8
	V <sub>SS</sub>	GND			P2.6-13
	V <sub>CC</sub>	V <sub>CC</sub>			
P1.4-6	TA0.2	CCI2A	CCR2	TA2	P1.4-6
PinOsc	TA0.2	CCI2B			
	V <sub>SS</sub>	GND			
	V <sub>CC</sub>	V <sub>CC</sub>			

(1) Only one pin-oscillator must be enabled at a time.

### USI

The universal serial interface (USI) module is used for serial data communication and provides the basic hardware for synchronous communication protocols like SPI and I2C.

**Peripheral File Map**
**Table 13. Peripherals With Word Access**

<b>MODULE</b>	<b>REGISTER DESCRIPTION</b>	<b>REGISTER NAME</b>	<b>OFFSET</b>
<b>Timer0_A3</b>	Capture/compare register	TACCR2	0176h
	Capture/compare register	TACCR1	0174h
	Capture/compare register	TACCR0	0172h
	Timer_A register	TAR	0170h
	Capture/compare control	TACCTL2	0166h
	Capture/compare control	TACCTL1	0164h
	Capture/compare control	TACCTL0	0162h
	Timer_A control	TACTL	0160h
	Timer_A interrupt vector	TAIV	012Eh
<b>Flash Memory</b>	Flash control 3	FCTL3	012Ch
	Flash control 2	FCTL2	012Ah
	Flash control 1	FCTL1	0128h
<b>Watchdog Timer+</b>	Watchdog/timer control	WDTCTL	0120h

**Table 14. Peripherals With Byte Access**

MODULE	REGISTER DESCRIPTION	REGISTER NAME	OFFSET
<b>USI</b>	USI control 0	USICTL0	078h
	USI control 1	USICTL1	079h
	USI clock control	USICKCTL	07Ah
	USI bit counter	USICNT	07Bh
	USI shift register	USISR	07Ch
<b>Basic Clock System+</b>	Basic clock system control 3	BCSCTL3	053h
	Basic clock system control 2	BCSCTL2	058h
	Basic clock system control 1	BCSCTL1	057h
	DCO clock frequency control	DCOCTL	056h
<b>Port P2</b>	Port P2 selection 2	P2SEL2	042h
	Port P2 resistor enable	P2REN	02Fh
	Port P2 selection	P2SEL	02Eh
	Port P2 interrupt enable	P2IE	02Dh
	Port P2 interrupt edge select	P2IES	02Ch
	Port P2 interrupt flag	P2IFG	02Bh
	Port P2 direction	P2DIR	02Ah
	Port P2 output	P2OUT	029h
	Port P2 input	P2IN	028h
<b>Port P1</b>	Port P1 selection 2	P1SEL2	041h
	Port P1 resistor enable	P1REN	027h
	Port P1 selection	P1SEL	026h
	Port P1 interrupt enable	P1IE	025h
	Port P1 interrupt edge select	P1IES	024h
	Port P1 interrupt flag	P1IFG	023h
	Port P1 direction	P1DIR	022h
	Port P1 output	P1OUT	021h
	Port P1 input	P1IN	020h
<b>Special Function</b>	SFR interrupt flag 2	IFG2	003h
	SFR interrupt flag 1	IFG1	002h
	SFR interrupt enable 2	IE2	001h
	SFR interrupt enable 1	IE1	000h



## Absolute Maximum Ratings<sup>(1)</sup>

Voltage applied at $V_{CC}$ to $V_{SS}$		-0.3 V to 4.1 V
Voltage applied to any pin <sup>(2)</sup>		-0.3 V to $V_{CC} + 0.3$ V
Diode current at any device pin		±2 mA
Storage temperature range, $T_{stg}$ <sup>(3)</sup>	Unprogrammed device	-55°C to 150°C
	Programmed device	-55°C to 150°C

- (1) Stresses beyond those listed under "absolute maximum ratings" may cause permanent damage to the device. These are stress ratings only, and functional operation of the device at these or any other conditions beyond those indicated under "recommended operating conditions" is not implied. Exposure to absolute-maximum-rated conditions for extended periods may affect device reliability.
- (2) All voltages referenced to  $V_{SS}$ . The JTAG fuse-blow voltage,  $V_{FB}$ , is allowed to exceed the absolute maximum rating. The voltage is applied to the TEST pin when blowing the JTAG fuse.
- (3) Higher temperature may be applied during board soldering according to the current JEDEC J-STD-020 specification with peak reflow temperatures not higher than classified on the device label on the shipping boxes or reels.

## Thermal Information

THERMAL METRIC		MSP430G2302	UNITS
		PW	
		14 PINS	
$\theta_{JA}$	Junction-to-ambient thermal resistance <sup>(1)</sup>	98.7	°C/W
$\theta_{JCTop}$	Junction-to-case (top) thermal resistance <sup>(2)</sup>	26.8	
$\theta_{JB}$	Junction-to-board thermal resistance <sup>(3)</sup>	41.2	
$\psi_{JT}$	Junction-to-top characterization parameter <sup>(4)</sup>	1.1	
$\psi_{JB}$	Junction-to-board characterization parameter <sup>(5)</sup>	40.5	
$\theta_{JCbott}$	Junction-to-case (bottom) thermal resistance <sup>(6)</sup>	N/A	

- (1) 在 JESD51-2a 描述的环境中，按照 JESD51-7 的指定，在一个 JEDEC 标准高 K 电路板上进行仿真，从而获得自然对流条件下的结至环境热阻。
- (2) 通过在封装顶部模拟一个冷板测试来获得结至芯片外壳（顶部）的热阻。不存在特定的 JEDEC 标准测试，但可在 ANSI SEMI 标准 G30-88 中找到内容接近的说明。
- (3) 按照 JESD51-8 中的说明，通过在配有用于控制 PCB 温度的环形冷板夹具的环境中进行仿真，以获得结板热阻。
- (4) 结至顶部特征参数， $\psi_{JT}$ ，估算真实系统中器件的结温，并使用 JESD51-2a（第 6 章和第 7 章）中描述的程序从仿真数据中提取出该参数以便获得  $\theta_{JA}$ 。
- (5) 结至电路板特征参数， $\psi_{JB}$ ，估算真实系统中器件的结温，并使用 JESD51-2a（第 6 章和第 7 章）中描述的程序从仿真数据中提取出该参数以便获得  $\theta_{JA}$ 。
- (6) 通过在外露（电源）焊盘上进行冷板测试仿真来获得结至芯片外壳（底部）热阻。不存在特定的 JEDEC 标准测试，但可在 ANSI SEMI 标准 G30-88 中找到内容接近的说明。

### Recommended Operating Conditions

		MIN	NOM	MAX	UNIT	
V <sub>CC</sub>	Supply voltage	During program execution		1.8	3.6	V
		During flash programming/erase		2.2	3.6	
V <sub>SS</sub>	Supply voltage			0	V	
T <sub>A</sub>	Operating free-air temperature	-40		85	°C	
f <sub>SYSTEM</sub>	Processor frequency (maximum MCLK frequency using the USART module) <sup>(1)(2)</sup>	V <sub>CC</sub> = 1.8 V, Duty cycle = 50% ± 10%		dc	6	MHz
		V <sub>CC</sub> = 2.7 V, Duty cycle = 50% ± 10%		dc	12	
		V <sub>CC</sub> = 3.3 V, Duty cycle = 50% ± 10%		dc	16	

- (1) The MSP430 CPU is clocked directly with MCLK. Both the high and low phase of MCLK must not exceed the pulse width of the specified maximum frequency.
- (2) Modules might have a different maximum input clock specification. See the specification of the respective module in this data sheet.

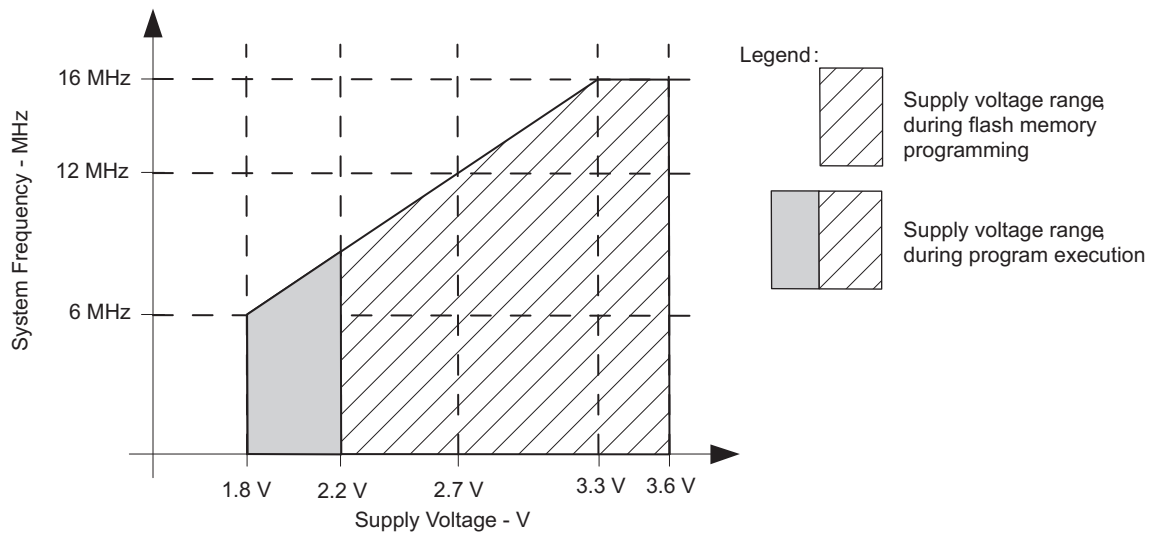

Note: Minimum processor frequency is defined by system clock. Flash program or erase operations require a minimum V<sub>CC</sub> of 2.2 V.

**Figure 1. Safe Operating Area**

**Electrical Characteristics**

**Active Mode Supply Current Into  $V_{CC}$  Excluding External Current**

over recommended ranges of supply voltage and operating free-air temperature (unless otherwise noted)<sup>(1)(2)</sup>

PARAMETER	TEST CONDITIONS	$V_{CC}$	MIN	TYP	MAX	UNIT
$I_{AM,1MHz}$ Active mode (AM) current (1 MHz)	$f_{DCO} = f_{MCLK} = f_{SMCLK} = 1\text{ MHz}$ , $f_{ACLK} = 32768\text{ Hz}$ , Program executes in flash, BCSCTL1 = CALBC1_1MHZ, DCOCTL = CALDCO_1MHZ, CPUOFF = 0, SCG0 = 0, SCG1 = 0, OSCOFF = 0	2.2 V		220		$\mu\text{A}$
		3 V		320	400	

- (1) All inputs are tied to 0 V or to  $V_{CC}$ . Outputs do not source or sink any current.
- (2) The currents are characterized with a Micro Crystal CC4V-T1A SMD crystal with a load capacitance of 9 pF. The internal and external load capacitance is chosen to closely match the required 9 pF.

**Typical Characteristics – Active Mode Supply Current (Into  $V_{CC}$ )**

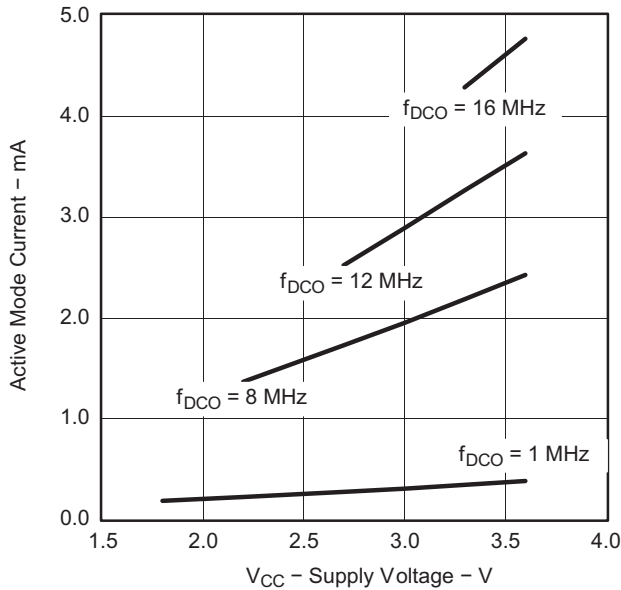

**Figure 2. Active Mode Current vs  $V_{CC}$ ,  $T_A = 25^\circ\text{C}$**

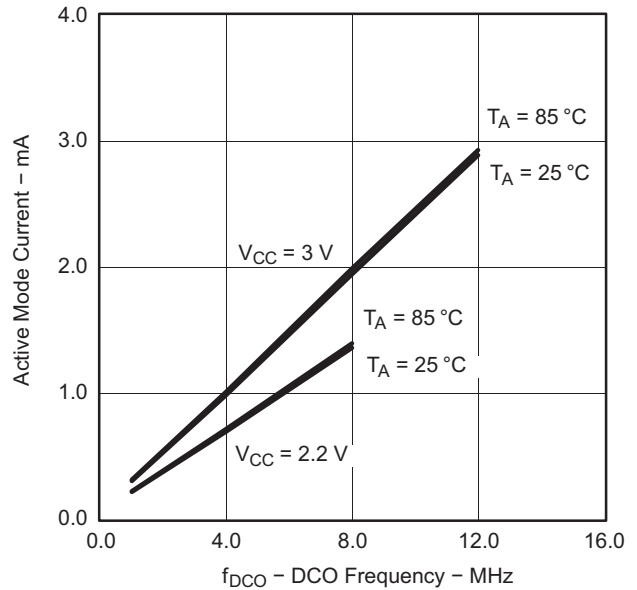

**Figure 3. Active Mode Current vs DCO Frequency**

### Low-Power Mode Supply Currents (Into $V_{CC}$ ) Excluding External Current

over recommended ranges of supply voltage and operating free-air temperature (unless otherwise noted)<sup>(1) (2)</sup>

PARAMETER	TEST CONDITIONS	$T_A$	$V_{CC}$	MIN	TYP	MAX	UNIT
$I_{LPM0,1MHz}$ Low-power mode 0 (LPM0) current <sup>(3)</sup>	$f_{MCLK} = 0$ MHz, $f_{SMCLK} = f_{DCO} = 1$ MHz, $f_{ACLK} = 32768$ Hz, BCSCTL1 = CALBC1_1MHZ, DCOCTL = CALDCO_1MHZ, CPUOFF = 1, SCG0 = 0, SCG1 = 0, OSCOFF = 0	25°C	2.2 V		55		$\mu$ A
$I_{LPM2}$ Low-power mode 2 (LPM2) current <sup>(4)</sup>	$f_{MCLK} = f_{SMCLK} = 0$ MHz, $f_{DCO} = 1$ MHz, $f_{ACLK} = 32768$ Hz, BCSCTL1 = CALBC1_1MHZ, DCOCTL = CALDCO_1MHZ, CPUOFF = 1, SCG0 = 0, SCG1 = 1, OSCOFF = 0	25°C	2.2 V		22		$\mu$ A
$I_{LPM3,LFXT1}$ Low-power mode 3 (LPM3) current <sup>(4)</sup>	$f_{DCO} = f_{MCLK} = f_{SMCLK} = 0$ MHz, $f_{ACLK} = 32768$ Hz, CPUOFF = 1, SCG0 = 1, SCG1 = 1, OSCOFF = 0	25°C	2.2 V		0.7	1.0	$\mu$ A
$I_{LPM3,VLO}$ Low-power mode 3 current, (LPM3) <sup>(4)</sup>	$f_{DCO} = f_{MCLK} = f_{SMCLK} = 0$ MHz, $f_{ACLK}$ from internal LF oscillator (VLO), CPUOFF = 1, SCG0 = 1, SCG1 = 1, OSCOFF = 0	25°C	2.2 V		0.5	0.7	$\mu$ A
$I_{LPM4}$ Low-power mode 4 (LPM4) current <sup>(5)</sup>	$f_{DCO} = f_{MCLK} = f_{SMCLK} = 0$ MHz, $f_{ACLK} = 0$ Hz, CPUOFF = 1, SCG0 = 1, SCG1 = 1, OSCOFF = 1	25°C	2.2 V		0.1	0.5	$\mu$ A
		85°C	2.2 V		0.8	1.5	$\mu$ A

- (1) All inputs are tied to 0 V or to  $V_{CC}$ . Outputs do not source or sink any current.
- (2) The currents are characterized with a Micro Crystal CC4V-T1A SMD crystal with a load capacitance of 9 pF.
- (3) Current for brownout and WDT clocked by SMCLK included.
- (4) Current for brownout and WDT clocked by ACLK included.
- (5) Current for brownout included.

### Typical Characteristics Low-Power Mode Supply Currents

over recommended ranges of supply voltage and operating free-air temperature (unless otherwise noted)

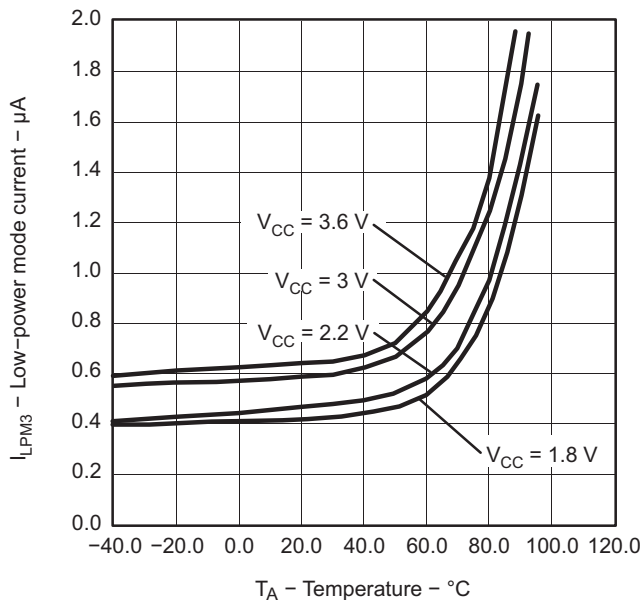

Figure 4. LPM3 Current vs Temperature

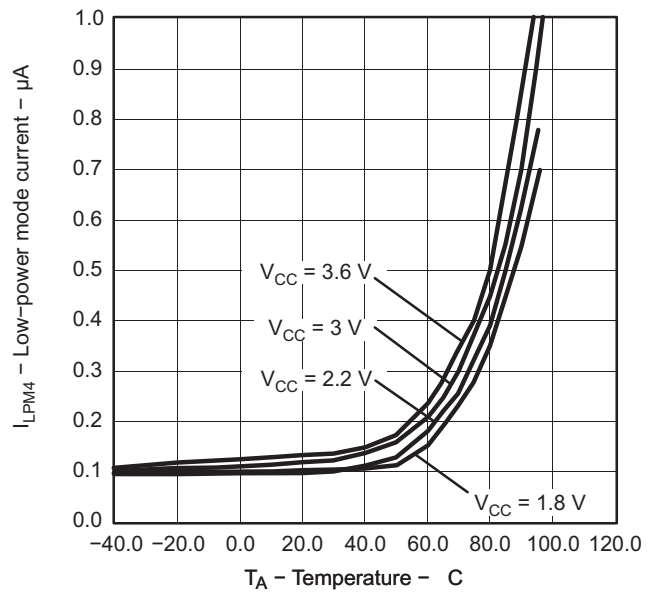

Figure 5. LPM4 Current vs Temperature

## Schmitt-Trigger Inputs – Ports Px<sup>(1)</sup>

over recommended ranges of supply voltage and operating free-air temperature (unless otherwise noted)

PARAMETER		TEST CONDITIONS	V <sub>CC</sub>	MIN	TYP	MAX	UNIT
V <sub>IT+</sub>	Positive-going input threshold voltage			0.45 V <sub>CC</sub>		0.75 V <sub>CC</sub>	V
			3 V	1.35		2.25	
V <sub>IT-</sub>	Negative-going input threshold voltage			0.25 V <sub>CC</sub>		0.55 V <sub>CC</sub>	V
			3 V	0.75		1.65	
V <sub>hys</sub>	Input voltage hysteresis (V <sub>IT+</sub> – V <sub>IT-</sub> )		3 V	0.3		1	V
R <sub>Pull</sub>	Pullup/pulldown resistor	For pullup: V <sub>IN</sub> = V <sub>SS</sub> For pulldown: V <sub>IN</sub> = V <sub>CC</sub>	3 V	20	35	50	kΩ
C <sub>I</sub>	Input capacitance	V <sub>IN</sub> = V <sub>SS</sub> or V <sub>CC</sub>			5		pF

- (1) An external signal sets the interrupt flag every time the minimum interrupt pulse width  $t_{(int)}$  is met. It may be set even with trigger signals shorter than  $t_{(int)}$ .

## Leakage Current – Ports Px

over recommended ranges of supply voltage and operating free-air temperature (unless otherwise noted)

PARAMETER		TEST CONDITIONS	V <sub>CC</sub>	MIN	MAX	UNIT
I <sub>lkg(Px.x)</sub>	High-impedance leakage current	See <sup>(1)</sup> and <sup>(2)</sup>	3 V		±50	nA

- (1) The leakage current is measured with V<sub>SS</sub> or V<sub>CC</sub> applied to the corresponding pin(s), unless otherwise noted.  
 (2) The leakage of the digital port pins is measured individually. The port pin is selected for input, and the pullup/pulldown resistor is disabled.

## Outputs – Ports Px

over recommended ranges of supply voltage and operating free-air temperature (unless otherwise noted)

PARAMETER		TEST CONDITIONS	V <sub>CC</sub>	MIN	TYP	MAX	UNIT
V <sub>OH</sub>	High-level output voltage	I <sub>(OHmax)</sub> = –6 mA <sup>(1)</sup>	3 V		V <sub>CC</sub> – 0.3		V
V <sub>OL</sub>	Low-level output voltage	I <sub>(OLmax)</sub> = 6 mA <sup>(1)</sup>	3 V		V <sub>SS</sub> + 0.3		V

- (1) The maximum total current, I<sub>(OHmax)</sub> and I<sub>(OLmax)</sub>, for all outputs combined should not exceed ±48 mA to hold the maximum voltage drop specified.

## Output Frequency – Ports Px

over recommended ranges of supply voltage and operating free-air temperature (unless otherwise noted)

PARAMETER		TEST CONDITIONS	V <sub>CC</sub>	MIN	TYP	MAX	UNIT
f <sub>Px,y</sub>	Port output frequency (with load)	Px.y, C <sub>L</sub> = 20 pF, R <sub>L</sub> = 1 kΩ <sup>(1)</sup> <sup>(2)</sup>	3 V		12		MHz
f <sub>Port_CLK</sub>	Clock output frequency	Px.y, C <sub>L</sub> = 20 pF <sup>(2)</sup>	3 V		16		MHz

- (1) A resistive divider with two 0.5-kΩ resistors between V<sub>CC</sub> and V<sub>SS</sub> is used as load. The output is connected to the center tap of the divider.  
 (2) The output voltage reaches at least 10% and 90% V<sub>CC</sub> at the specified toggle frequency.

### Typical Characteristics – Outputs

over recommended ranges of supply voltage and operating free-air temperature (unless otherwise noted)

TYPICAL LOW-LEVEL OUTPUT CURRENT  
vs  
LOW-LEVEL OUTPUT VOLTAGE

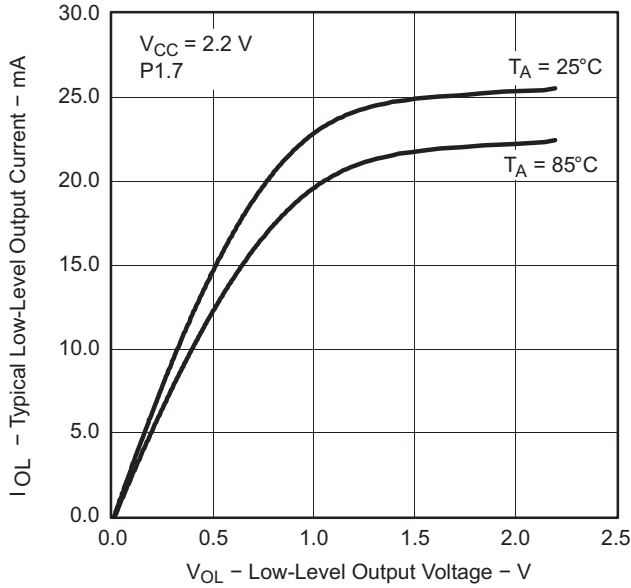

Figure 6.

TYPICAL LOW-LEVEL OUTPUT CURRENT  
vs  
LOW-LEVEL OUTPUT VOLTAGE

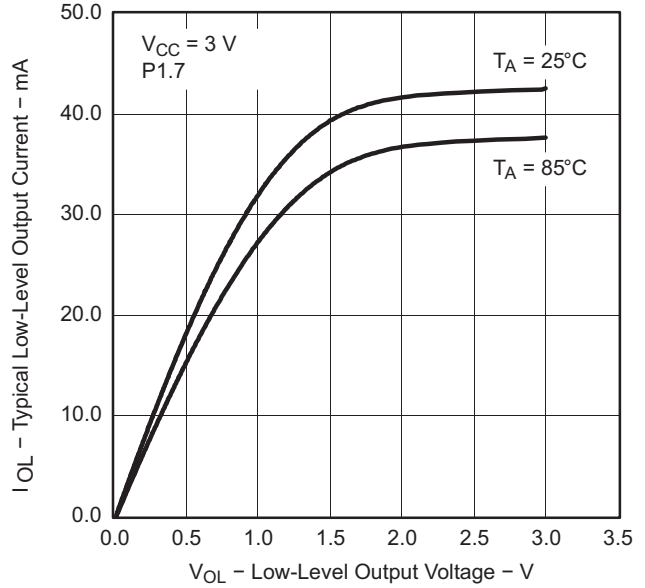

Figure 7.

TYPICAL HIGH-LEVEL OUTPUT CURRENT  
vs  
HIGH-LEVEL OUTPUT VOLTAGE

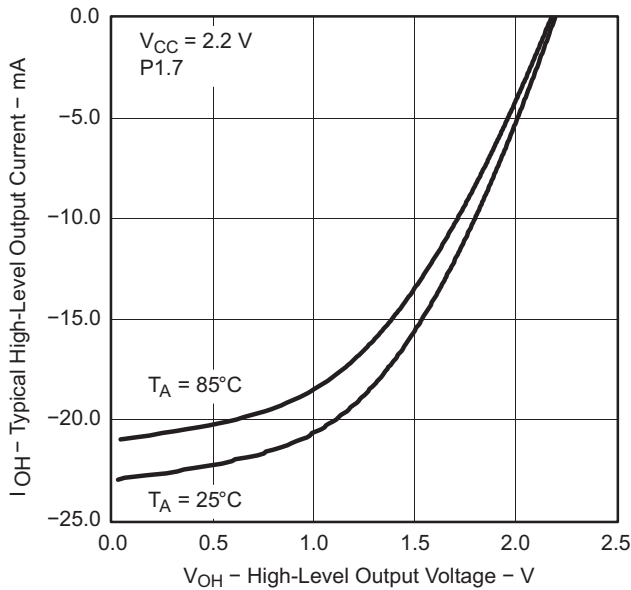

Figure 8.

TYPICAL HIGH-LEVEL OUTPUT CURRENT  
vs  
HIGH-LEVEL OUTPUT VOLTAGE

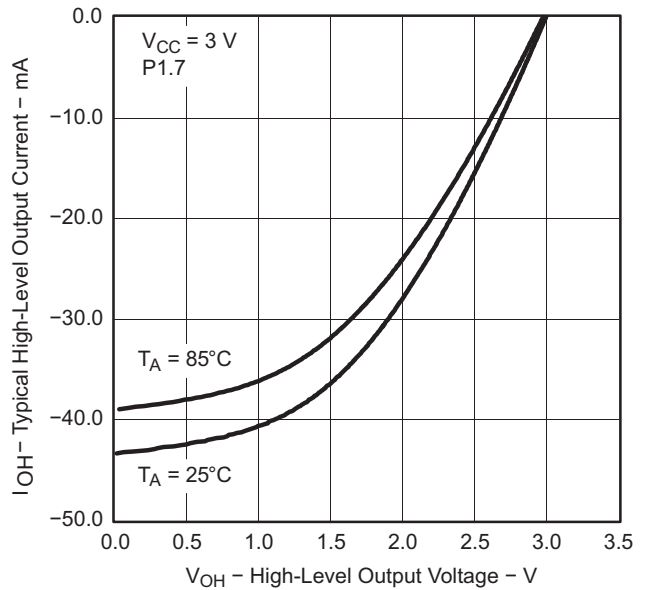

Figure 9.

### Pin-Oscillator Frequency – Ports Px

over recommended ranges of supply voltage and operating free-air temperature (unless otherwise noted)

PARAMETER	TEST CONDITIONS	V <sub>CC</sub>	MIN	TYP	MAX	UNIT
f <sub>oP1.x</sub> Port output oscillation frequency	P1.y, C <sub>L</sub> = 10 pF, R <sub>L</sub> = 100 kΩ <sup>(1)(2)</sup>	3 V	1400			kHz
	P1.y, C <sub>L</sub> = 20 pF, R <sub>L</sub> = 100 kΩ <sup>(1)(2)</sup>		900			
f <sub>oP2.x</sub> Port output oscillation frequency	P2.0 to P2.5, C <sub>L</sub> = 10 pF, R <sub>L</sub> = 100 kΩ <sup>(1)(2)</sup>	3 V	1800			kHz
	P2.0 to P2.5, C <sub>L</sub> = 20 pF, R <sub>L</sub> = 100 kΩ <sup>(1)(2)</sup>		1000			
f <sub>oP2.6/7</sub> Port output oscillation frequency	P2.6 and P2.7, C <sub>L</sub> = 20 pF, R <sub>L</sub> = 100 kΩ <sup>(1)(2)</sup>	3 V	700			kHz

- (1) A resistive divider with two 100-kΩ resistors between V<sub>CC</sub> and V<sub>SS</sub> is used as load. The output is connected to the center tap of the divider.
- (2) The output voltage oscillates with a typical amplitude of 700 mV at the specified toggle frequency.

### Typical Characteristics – Pin-Oscillator Frequency

TYPICAL OSCILLATING FREQUENCY  
vs  
LOAD CAPACITANCE

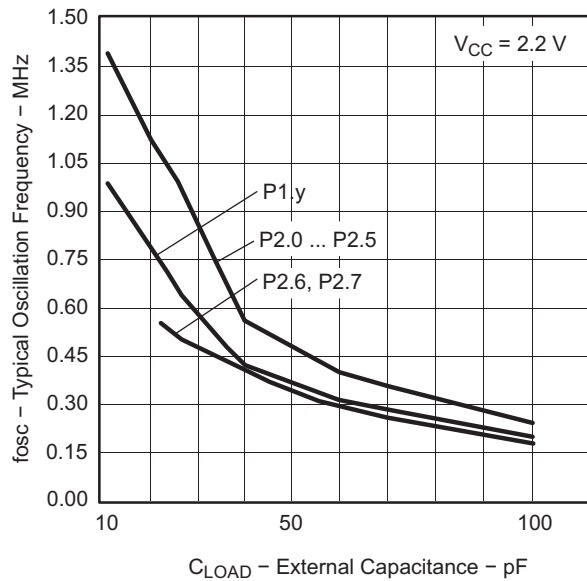

Figure 10.

TYPICAL OSCILLATING FREQUENCY  
vs  
LOAD CAPACITANCE

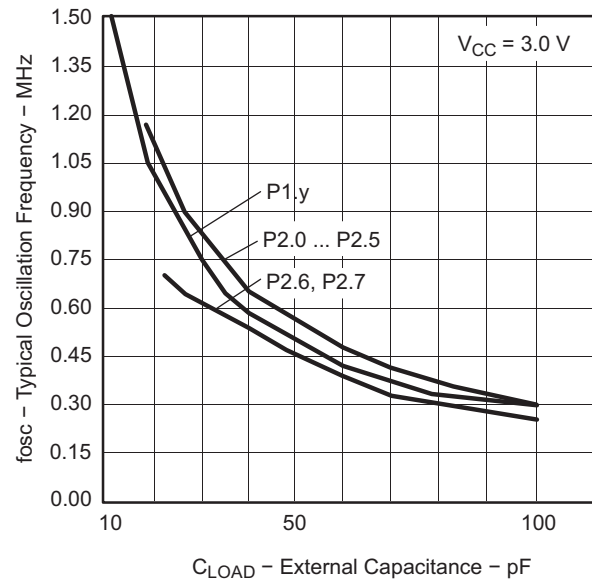

Figure 11.

### POR/Brownout Reset (BOR)<sup>(1)</sup>

over recommended ranges of supply voltage and operating free-air temperature (unless otherwise noted)

PARAMETER	TEST CONDITIONS	V <sub>CC</sub>	MIN	TYP	MAX	UNIT
V <sub>CC(start)</sub>	See Figure 12			0.7 × V <sub>(B_IT-)</sub>		V
V <sub>(B_IT-)</sub>	See Figure 12 through Figure 14			1.40		V
V <sub>hys(B_IT-)</sub>	See Figure 12			140		mV
t <sub>d(BOR)</sub>	See Figure 12				2000	μs
t <sub>(reset)</sub>	Pulse length needed at RST/NMI pin to accepted reset internally	2.2 V	2			μs

(1) The current consumption of the brownout module is already included in the I<sub>CC</sub> current consumption data. The voltage level V<sub>(B\_IT-)</sub> + V<sub>hys(B\_IT-)</sub> is ≤ 1.8 V.

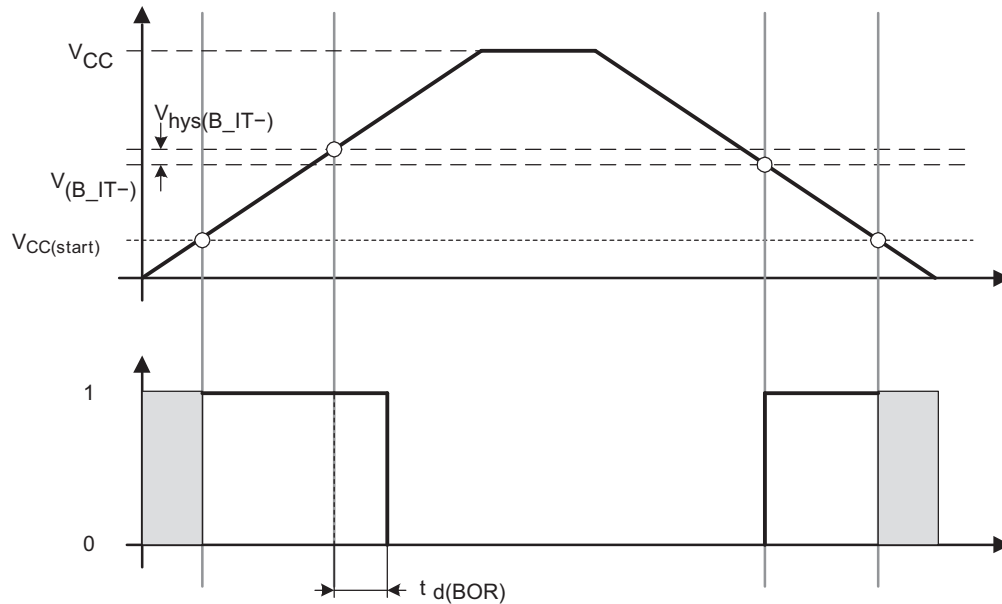

Figure 12. POR/Brownout Reset (BOR) vs Supply Voltage



Typical Characteristics – POR/Brownout Reset (BOR)

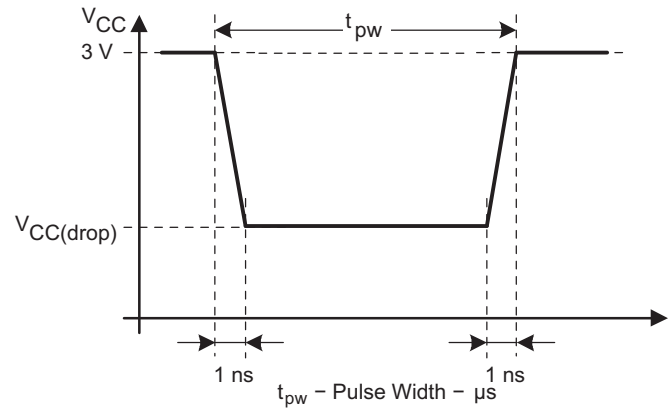
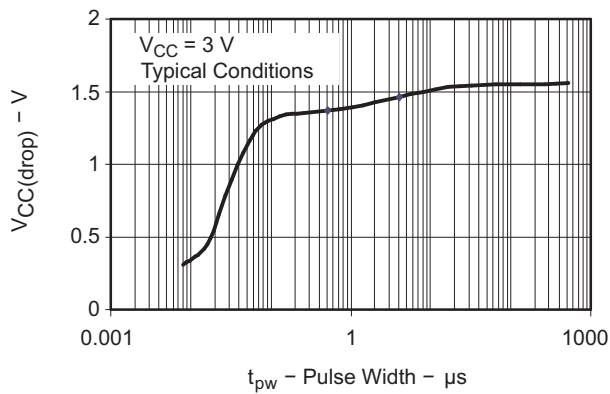

Figure 13.  $V_{CC(drop)}$  Level With a Square Voltage Drop to Generate a POR/Brownout Signal

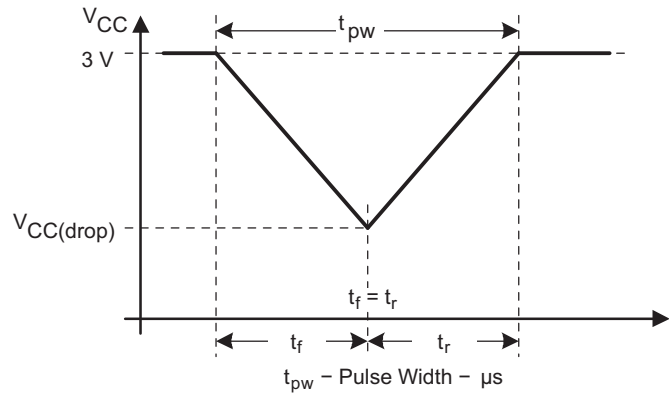
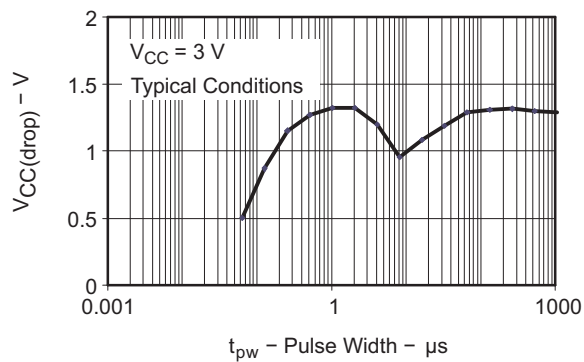

Figure 14.  $V_{CC(drop)}$  Level With a Triangle Voltage Drop to Generate a POR/Brownout Signal

## DCO Frequency

over recommended ranges of supply voltage and operating free-air temperature (unless otherwise noted)

PARAMETER		TEST CONDITIONS	V <sub>CC</sub>	MIN	TYP	MAX	UNIT
V <sub>CC</sub>	Supply voltage	RSELx < 14		1.8		3.6	V
		RSELx = 14		2.2		3.6	V
		RSELx = 15		3		3.6	V
f <sub>DCO(0,0)</sub>	DCO frequency (0, 0)	RSELx = 0, DCOx = 0, MODx = 0	3 V	0.06		0.14	MHz
f <sub>DCO(0,3)</sub>	DCO frequency (0, 3)	RSELx = 0, DCOx = 3, MODx = 0	3 V	0.07		0.17	MHz
f <sub>DCO(1,3)</sub>	DCO frequency (1, 3)	RSELx = 1, DCOx = 3, MODx = 0	3 V		0.15		MHz
f <sub>DCO(2,3)</sub>	DCO frequency (2, 3)	RSELx = 2, DCOx = 3, MODx = 0	3 V		0.21		MHz
f <sub>DCO(3,3)</sub>	DCO frequency (3, 3)	RSELx = 3, DCOx = 3, MODx = 0	3 V		0.30		MHz
f <sub>DCO(4,3)</sub>	DCO frequency (4, 3)	RSELx = 4, DCOx = 3, MODx = 0	3 V		0.41		MHz
f <sub>DCO(5,3)</sub>	DCO frequency (5, 3)	RSELx = 5, DCOx = 3, MODx = 0	3 V		0.58		MHz
f <sub>DCO(6,3)</sub>	DCO frequency (6, 3)	RSELx = 6, DCOx = 3, MODx = 0	3 V	0.54		1.06	MHz
f <sub>DCO(7,3)</sub>	DCO frequency (7, 3)	RSELx = 7, DCOx = 3, MODx = 0	3 V	0.80		1.50	MHz
f <sub>DCO(8,3)</sub>	DCO frequency (8, 3)	RSELx = 8, DCOx = 3, MODx = 0	3 V		1.6		MHz
f <sub>DCO(9,3)</sub>	DCO frequency (9, 3)	RSELx = 9, DCOx = 3, MODx = 0	3 V		2.3		MHz
f <sub>DCO(10,3)</sub>	DCO frequency (10, 3)	RSELx = 10, DCOx = 3, MODx = 0	3 V		3.4		MHz
f <sub>DCO(11,3)</sub>	DCO frequency (11, 3)	RSELx = 11, DCOx = 3, MODx = 0	3 V		4.25		MHz
f <sub>DCO(12,3)</sub>	DCO frequency (12, 3)	RSELx = 12, DCOx = 3, MODx = 0	3 V	4.30		7.30	MHz
f <sub>DCO(13,3)</sub>	DCO frequency (13, 3)	RSELx = 13, DCOx = 3, MODx = 0	3 V	6.00		9.60	MHz
f <sub>DCO(14,3)</sub>	DCO frequency (14, 3)	RSELx = 14, DCOx = 3, MODx = 0	3 V	8.60		13.9	MHz
f <sub>DCO(15,3)</sub>	DCO frequency (15, 3)	RSELx = 15, DCOx = 3, MODx = 0	3 V	12.0		18.5	MHz
f <sub>DCO(15,7)</sub>	DCO frequency (15, 7)	RSELx = 15, DCOx = 7, MODx = 0	3 V	16.0		26.0	MHz
S <sub>RSEL</sub>	Frequency step between range RSEL and RSEL+1	$S_{RSEL} = f_{DCO(RSEL+1,DCO)} / f_{DCO(RSEL,DCO)}$	3 V		1.35		ratio
S <sub>DCO</sub>	Frequency step between tap DCO and DCO+1	$S_{DCO} = f_{DCO(RSEL,DCO+1)} / f_{DCO(RSEL,DCO)}$	3 V		1.08		ratio
Duty cycle		Measured at SMCLK output	3 V		50		%

## Calibrated DCO Frequencies – Tolerance

over recommended ranges of supply voltage and operating free-air temperature (unless otherwise noted)

PARAMETER	TEST CONDITIONS	T <sub>A</sub>	V <sub>CC</sub>	MIN	TYP	MAX	UNIT
1-MHz tolerance over temperature <sup>(1)</sup>	BCSCTL1= CALBC1_1MHZ, DCOCTL = CALDCO_1MHZ, calibrated at 30°C and 3 V	0°C to 85°C	3 V	-3	±0.5	+3	%
1-MHz tolerance over V <sub>CC</sub>	BCSCTL1= CALBC1_1MHZ, DCOCTL = CALDCO_1MHZ, calibrated at 30°C and 3 V	30°C	1.8 V to 3.6 V	-3	±2	+3	%
1-MHz tolerance overall	BCSCTL1= CALBC1_1MHZ, DCOCTL = CALDCO_1MHZ, calibrated at 30°C and 3 V	-40°C to 85°C	1.8 V to 3.6 V	-6	±3	+6	%
8-MHz tolerance over temperature <sup>(1)</sup>	BCSCTL1= CALBC1_8MHZ, DCOCTL = CALDCO_8MHZ, calibrated at 30°C and 3 V	0°C to 85°C	3 V	-3	±0.5	+3	%
8-MHz tolerance over V <sub>CC</sub>	BCSCTL1= CALBC1_8MHZ, DCOCTL = CALDCO_8MHZ, calibrated at 30°C and 3 V	30°C	2.2 V to 3.6 V	-3	±2	+3	%
8-MHz tolerance overall	BCSCTL1= CALBC1_8MHZ, DCOCTL = CALDCO_8MHZ, calibrated at 30°C and 3 V	-40°C to 85°C	2.2 V to 3.6 V	-6	±3	+6	%
12-MHz tolerance over temperature <sup>(1)</sup>	BCSCTL1= CALBC1_12MHZ, DCOCTL = CALDCO_12MHZ, calibrated at 30°C and 3 V	0°C to 85°C	3 V	-3	±0.5	+3	%
12-MHz tolerance over V <sub>CC</sub>	BCSCTL1= CALBC1_12MHZ, DCOCTL = CALDCO_12MHZ, calibrated at 30°C and 3 V	30°C	2.7 V to 3.6 V	-3	±2	+3	%
12-MHz tolerance overall	BCSCTL1= CALBC1_12MHZ, DCOCTL = CALDCO_12MHZ, calibrated at 30°C and 3 V	-40°C to 85°C	2.7 V to 3.6 V	-6	±3	+6	%
16-MHz tolerance over temperature <sup>(1)</sup>	BCSCTL1= CALBC1_16MHZ, DCOCTL = CALDCO_16MHZ, calibrated at 30°C and 3 V	0°C to 85°C	3.3 V	-3	±0.5	+3	%
16-MHz tolerance over V <sub>CC</sub>	BCSCTL1= CALBC1_16MHZ, DCOCTL = CALDCO_16MHZ, calibrated at 30°C and 3 V	30°C	3.3 V to 3.6 V	-3	±2	+3	%
16-MHz tolerance overall	BCSCTL1= CALBC1_16MHZ, DCOCTL = CALDCO_16MHZ, calibrated at 30°C and 3 V	-40°C to 85°C	3.3 V to 3.6 V	-6	±3	+6	%

(1) This is the frequency change from the measured frequency at 30°C over temperature.

### Wake-Up From Lower-Power Modes (LPM3/4)

over recommended ranges of supply voltage and operating free-air temperature (unless otherwise noted)

PARAMETER	TEST CONDITIONS	V <sub>CC</sub>	MIN	TYP	MAX	UNIT
t <sub>DCO,LPM3/4</sub>	DCO clock wake-up time from LPM3/4 <sup>(1)</sup>	3 V		1.5		μs
t <sub>CPU,LPM3/4</sub>	CPU wake-up time from LPM3/4 <sup>(2)</sup>			1/f <sub>MCLK</sub> + t <sub>Clock,LPM3/4</sub>		

- (1) The DCO clock wake-up time is measured from the edge of an external wake-up signal (for example, a port interrupt) to the first clock edge observable externally on a clock pin (MCLK or SMCLK).
- (2) Parameter applicable only if DCOCLK is used for MCLK.

### Typical Characteristics – DCO Clock Wake-Up Time From LPM3/4

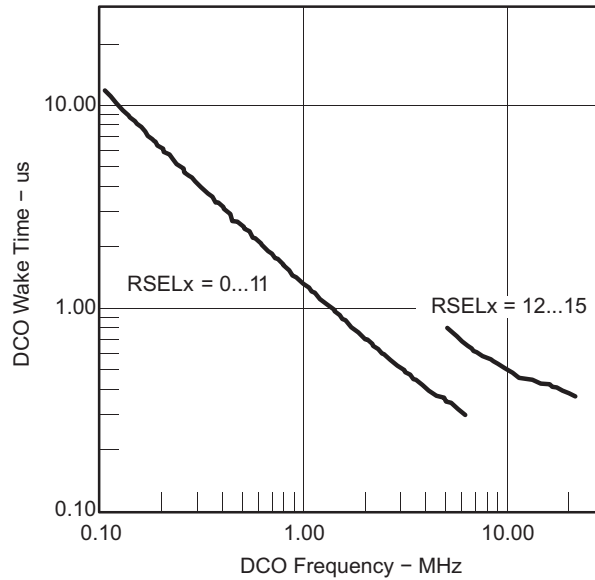

Figure 15. DCO Wake-Up Time From LPM3 vs DCO Frequency

## Crystal Oscillator, XT1, Low-Frequency Mode<sup>(1)</sup>

over recommended ranges of supply voltage and operating free-air temperature (unless otherwise noted)

PARAMETER		TEST CONDITIONS	V <sub>CC</sub>	MIN	TYP	MAX	UNIT
f <sub>LFXT1,LF</sub>	LFXT1 oscillator crystal frequency, LF mode 0, 1	XTS = 0, LFXT1Sx = 0 or 1	1.8 V to 3.6 V		32768		Hz
f <sub>LFXT1,LF,logic</sub>	LFXT1 oscillator logic level square wave input frequency, LF mode	XTS = 0, XCAPx = 0, LFXT1Sx = 3	1.8 V to 3.6 V	10000	32768	50000	Hz
O <sub>A,LF</sub>	Oscillation allowance for LF crystals	XTS = 0, LFXT1Sx = 0, f <sub>LFXT1,LF</sub> = 32768 Hz, C <sub>L,eff</sub> = 6 pF			500		kΩ
		XTS = 0, LFXT1Sx = 0, f <sub>LFXT1,LF</sub> = 32768 Hz, C <sub>L,eff</sub> = 12 pF			200		
C <sub>L,eff</sub>	Integrated effective load capacitance, LF mode <sup>(2)</sup>	XTS = 0, XCAPx = 0			1		pF
		XTS = 0, XCAPx = 1			5.5		
		XTS = 0, XCAPx = 2			8.5		
		XTS = 0, XCAPx = 3			11		
Duty cycle	LF mode	XTS = 0, Measured at P2.0/ACLK, f <sub>LFXT1,LF</sub> = 32768 Hz	2.2 V	30	50	70	%
f <sub>Fault,LF</sub>	Oscillator fault frequency, LF mode <sup>(3)</sup>	XTS = 0, XCAPx = 0, LFXT1Sx = 3 <sup>(4)</sup>	2.2 V	10		10000	Hz

- (1) To improve EMI on the XT1 oscillator, the following guidelines should be observed.
  - (a) Keep the trace between the device and the crystal as short as possible.
  - (b) Design a good ground plane around the oscillator pins.
  - (c) Prevent crosstalk from other clock or data lines into oscillator pins XIN and XOUT.
  - (d) Avoid running PCB traces underneath or adjacent to the XIN and XOUT pins.
  - (e) Use assembly materials and praxis to avoid any parasitic load on the oscillator XIN and XOUT pins.
  - (f) If conformal coating is used, ensure that it does not induce capacitive/resistive leakage between the oscillator pins.
  - (g) Do not route the XOUT line to the JTAG header to support the serial programming adapter as shown in other documentation. This signal is no longer required for the serial programming adapter.
- (2) Includes parasitic bond and package capacitance (approximately 2 pF per pin).  
Because the PCB adds additional capacitance, it is recommended to verify the correct load by measuring the ACLK frequency. For a correct setup, the effective load capacitance should always match the specification of the used crystal.
- (3) Frequencies below the MIN specification set the fault flag. Frequencies above the MAX specification do not set the fault flag. Frequencies in between might set the flag.
- (4) Measured with logic-level input frequency but also applies to operation with crystals.

## Internal Very-Low-Power Low-Frequency Oscillator (VLO)

over recommended ranges of supply voltage and operating free-air temperature (unless otherwise noted)

PARAMETER		T <sub>A</sub>	V <sub>CC</sub>	MIN	TYP	MAX	UNIT
f <sub>VLO</sub>	VLO frequency <sup>(1)</sup>	-40°C to 85°C	3 V	4	12	20	kHz
df <sub>VLO</sub> /dT	VLO frequency temperature drift	-40°C to 85°C	3 V		0.5		%/°C
df <sub>VLO</sub> /dV <sub>CC</sub>	VLO frequency supply voltage drift	25°C	1.8 V to 3.6 V		4		%/V

- (1) Ensured by design on specified temperature.

## Timer\_A

over recommended ranges of supply voltage and operating free-air temperature (unless otherwise noted)

PARAMETER		TEST CONDITIONS	V <sub>CC</sub>	MIN	TYP	MAX	UNIT
f <sub>TA</sub>	Timer_A input clock frequency	SMCLK Duty cycle = 50% ± 10%			f <sub>SYSTEM</sub>		MHz
t <sub>TA,cap</sub>	Timer_A capture timing	TA0, TA1	3 V	20			ns

### USI, Universal Serial Interface

over recommended ranges of supply voltage and operating free-air temperature (unless otherwise noted)

PARAMETER		TEST CONDITIONS	V <sub>CC</sub>	MIN	TYP	MAX	UNIT
f <sub>USI</sub>	USI module clock frequency	External: SCLK, Duty cycle = 50% ± 10%		f <sub>SYSTEM</sub>			MHz
f <sub>(SCLK)</sub>	Serial clock frequency, slave mode	SPI slave mode	3 V			6	MHz
V <sub>OL,I2C</sub>	Low-level output voltage on SDA and SCL	USI module in I2C mode, I <sub>(OLmax)</sub> = 1.5 mA	3 V	V <sub>SS</sub>		V <sub>SS</sub> + 0.4	V

### Typical Characteristics – USI Low-Level Output Voltage on SDA and SCL

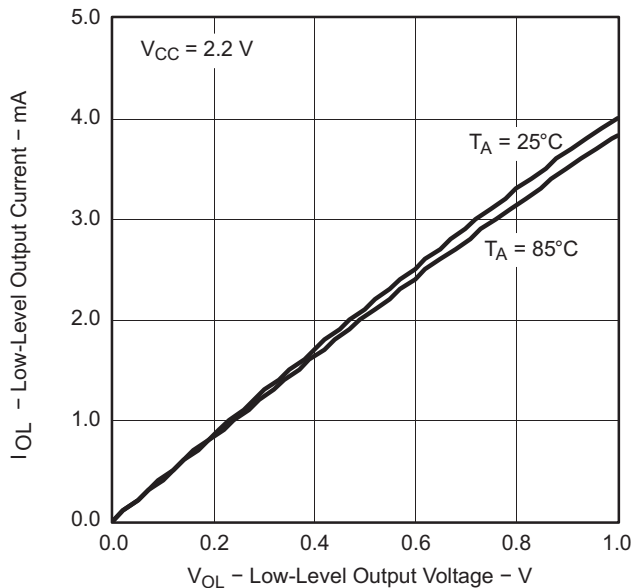

Figure 16. USI Low-Level Output Voltage vs Output Current

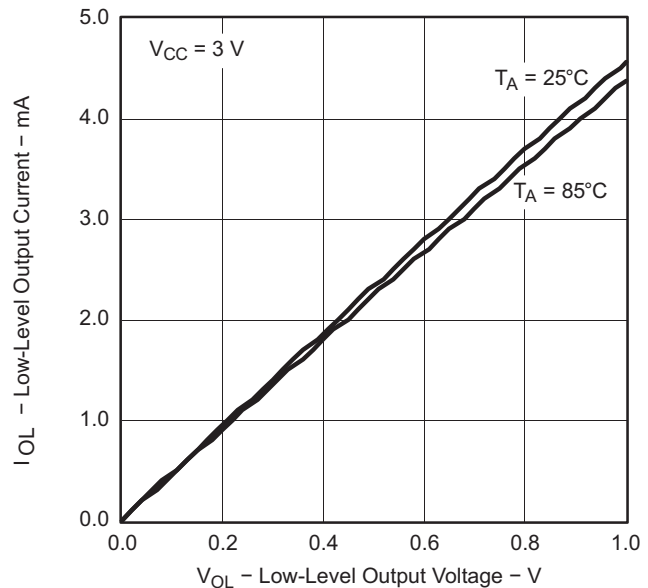

Figure 17. USI Low-Level Output Voltage vs Output Current

### Flash Memory

over recommended ranges of supply voltage and operating free-air temperature (unless otherwise noted)

PARAMETER		TEST CONDITIONS	V <sub>CC</sub>	MIN	TYP	MAX	UNIT
V <sub>CC(PGM/ERASE)</sub>	Program and erase supply voltage			2.2		3.6	V
f <sub>FTG</sub>	Flash timing generator frequency			257		476	kHz
I <sub>PGM</sub>	Supply current from V <sub>CC</sub> during program		2.2 V, 3.6 V		1	5	mA
I <sub>ERASE</sub>	Supply current from V <sub>CC</sub> during erase		2.2 V, 3.6 V		1	7	mA
t <sub>CPT</sub>	Cumulative program time <sup>(1)</sup>		2.2 V, 3.6 V			10	ms
t <sub>CMErase</sub>	Cumulative mass erase time		2.2 V, 3.6 V	20			ms
	Program and erase endurance			10 <sup>4</sup>	10 <sup>5</sup>		cycles
t <sub>Retention</sub>	Data retention duration	T <sub>J</sub> = 25°C		100			years
t <sub>Word</sub>	Word or byte program time	See <sup>(2)</sup>			30		t <sub>FTG</sub>
t <sub>Block, 0</sub>	Block program time for first byte or word	See <sup>(2)</sup>			25		t <sub>FTG</sub>
t <sub>Block, 1-63</sub>	Block program time for each additional byte or word	See <sup>(2)</sup>			18		t <sub>FTG</sub>
t <sub>Block, End</sub>	Block program end-sequence wait time	See <sup>(2)</sup>			6		t <sub>FTG</sub>
t <sub>Mass Erase</sub>	Mass erase time	See <sup>(2)</sup>			10593		t <sub>FTG</sub>

(1) The cumulative program time must not be exceeded when writing to a 64-byte flash block. This parameter applies to all programming methods: individual word or byte write mode and block write mode.

(2) These values are hardwired into the flash controller's state machine (t<sub>FTG</sub> = 1/f<sub>FTG</sub>).

**Flash Memory (continued)**

over recommended ranges of supply voltage and operating free-air temperature (unless otherwise noted)

PARAMETER		TEST CONDITIONS	V <sub>CC</sub>	MIN	TYP	MAX	UNIT
t <sub>Seg Erase</sub>	Segment erase time	See <sup>(2)</sup>			4819		t <sub>FTG</sub>

## RAM

over recommended ranges of supply voltage and operating free-air temperature (unless otherwise noted)

PARAMETER		TEST CONDITIONS	MIN	MAX	UNIT
$V_{(RAMh)}$	RAM retention supply voltage <sup>(1)</sup>	CPU halted	1.6		V

- (1) This parameter defines the minimum supply voltage  $V_{CC}$  when the data in RAM remains unchanged. No program execution should happen during this supply voltage condition.

## JTAG and Spy-Bi-Wire Interface

over recommended ranges of supply voltage and operating free-air temperature (unless otherwise noted)

PARAMETER		TEST CONDITIONS	$V_{CC}$	MIN	TYP	MAX	UNIT
$f_{SBW}$	Spy-Bi-Wire input frequency		2.2 V	0		20	MHz
$t_{SBW,Low}$	Spy-Bi-Wire low clock pulse length		2.2 V	0.025		15	$\mu$ s
$t_{SBW,En}$	Spy-Bi-Wire enable time (TEST high to acceptance of first clock edge <sup>(1)</sup> )		2.2 V			1	$\mu$ s
$t_{SBW,Ret}$	Spy-Bi-Wire return to normal operation time		2.2 V	15		100	$\mu$ s
$f_{TCK}$	TCK input frequency <sup>(2)</sup>		2.2 V	0		5	MHz
$R_{Internal}$	Internal pulldown resistance on TEST		2.2 V	25	60	90	k $\Omega$

- (1) Tools accessing the Spy-Bi-Wire interface need to wait for the maximum  $t_{SBW,En}$  time after pulling the TEST/SBWCLK pin high before applying the first SBWCLK clock edge.  
 (2)  $f_{TCK}$  may be restricted to meet the timing requirements of the module selected.

## JTAG Fuse<sup>(1)</sup>

over recommended ranges of supply voltage and operating free-air temperature (unless otherwise noted)

PARAMETER		TEST CONDITIONS	MIN	MAX	UNIT
$V_{CC(FB)}$	Supply voltage during fuse-blow condition	$T_A = 25^\circ\text{C}$	2.5		V
$V_{FB}$	Voltage level on TEST for fuse blow		6	7	V
$I_{FB}$	Supply current into TEST during fuse blow			100	mA
$t_{FB}$	Time to blow fuse			1	ms

- (1) Once the fuse is blown, no further access to the JTAG/Test, Spy-Bi-Wire, and emulation feature is possible, and JTAG is switched to bypass mode.



PIN SCHEMATICS

Port P1 Pin Schematic: P1.0 to P1.2, Input/Output With Schmitt Trigger

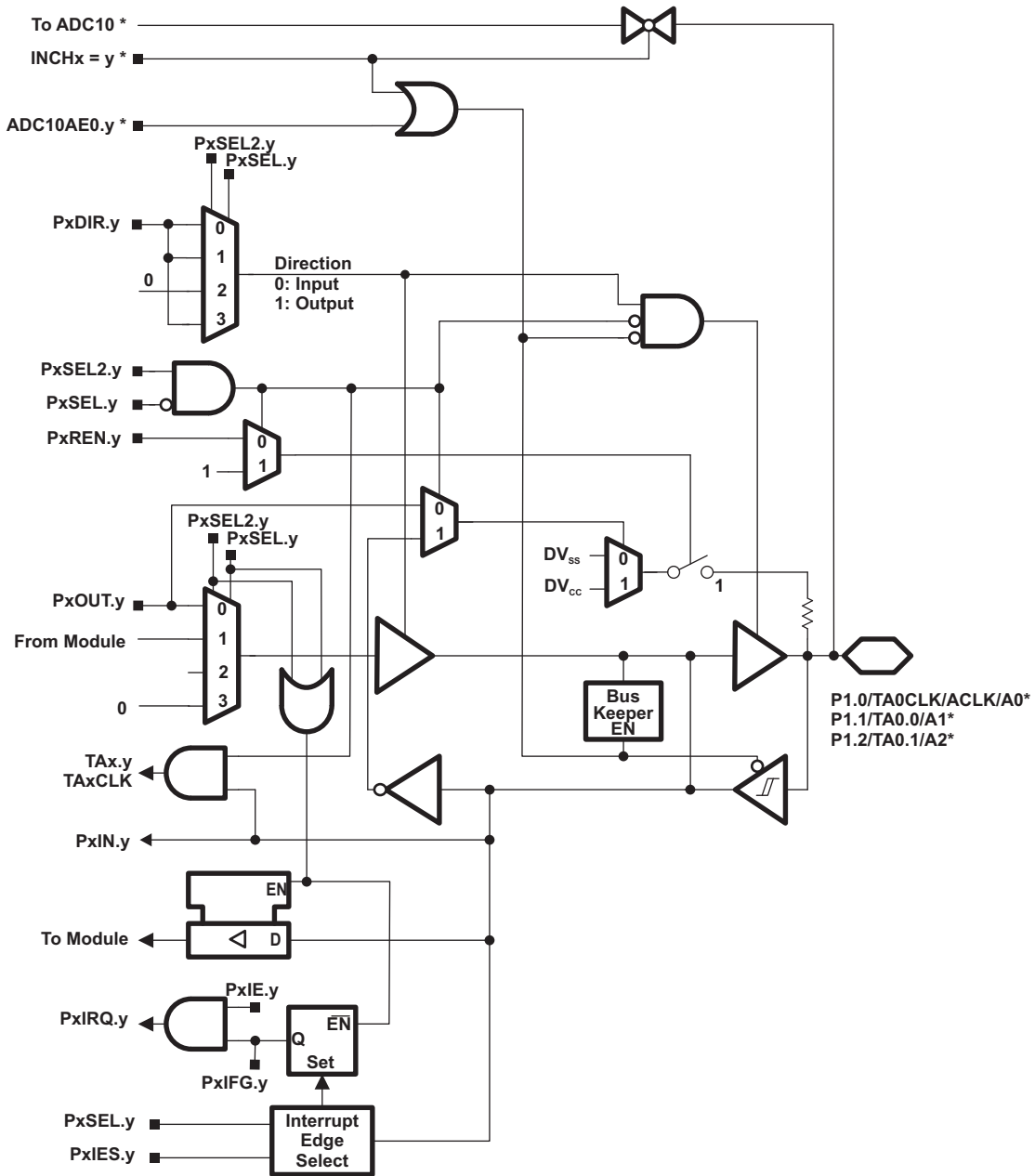

\* Note: MSP430G2x32 devices only. MSP430G2x02 devices have no ADC10.

**Table 15. Port P1 (P1.0 to P1.2) Pin Functions**

PIN NAME (P1.x)	x	FUNCTION	CONTROL BITS / SIGNALS <sup>(1)</sup>		
			P1DIR.x	P1SEL.x	P1SEL2.x
P1.0/ TA0CLK/ ACLK/ Pin Osc	0	P1.x (I/O)	I: 0; O: 1	0	0
		TA0.TACLK	0	1	0
		ACLK	1	1	0
		Capacitive sensing	x	0	1
P1.1/ TA0.0/ Pin Osc	1	P1.x (I/O)	I: 0; O: 1	0	0
		TA0.0	1	1	0
		TA0.CCI0A	0	1	0
		Capacitive sensing	X	0	1
P1.2/ TA0.1/ Pin Osc	2	P1.x (I/O)	I: 0; O: 1	0	0
		TA0.1	1	1	0
		TA0.CCI1A	0	1	0
		Capacitive sensing	X	0	1

(1) X = don't care

Port P1 Pin Schematic: P1.3, Input/Output With Schmitt Trigger

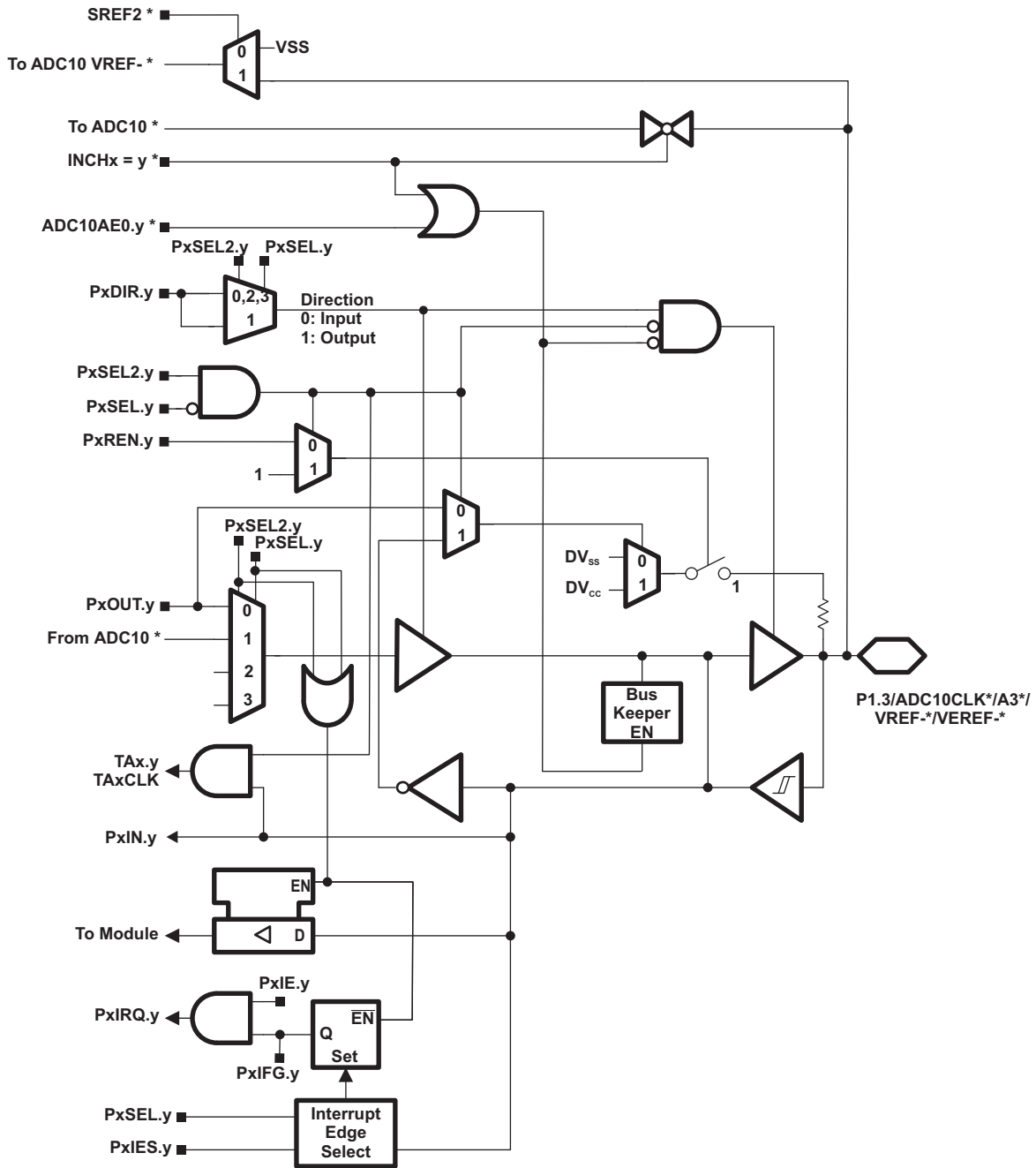

\* Note: MSP430G2x32 devices only. MSP430G2x02 devices have no ADC10.

**Table 16. Port P1 (P1.3) Pin Functions**

PIN NAME (P1.x)	x	FUNCTION	CONTROL BITS / SIGNALS <sup>(1)</sup>			
			P1DIR.x	P1SEL.x	P1SEL2.x	ADC10AE.x (INCH.x=1)
P1.3/ ADC10CLK/ A3/ VREF-/ VEREF-/ Pin Osc	3	P1.x (I/O)	I: 0; O: 1	0	0	0
ADC10CLK/		ADC10CLK	1	1	0	0
A3/		A3	X	X	X	1 (y = 3)
VREF-/ VEREF-/ Pin Osc		VREF- VEREF- Capacitive sensing	X X X	X X 0	X X 1	1 1 0

(1) X = don't care

Port P1 Pin Schematic: P1.4, Input/Output With Schmitt Trigger

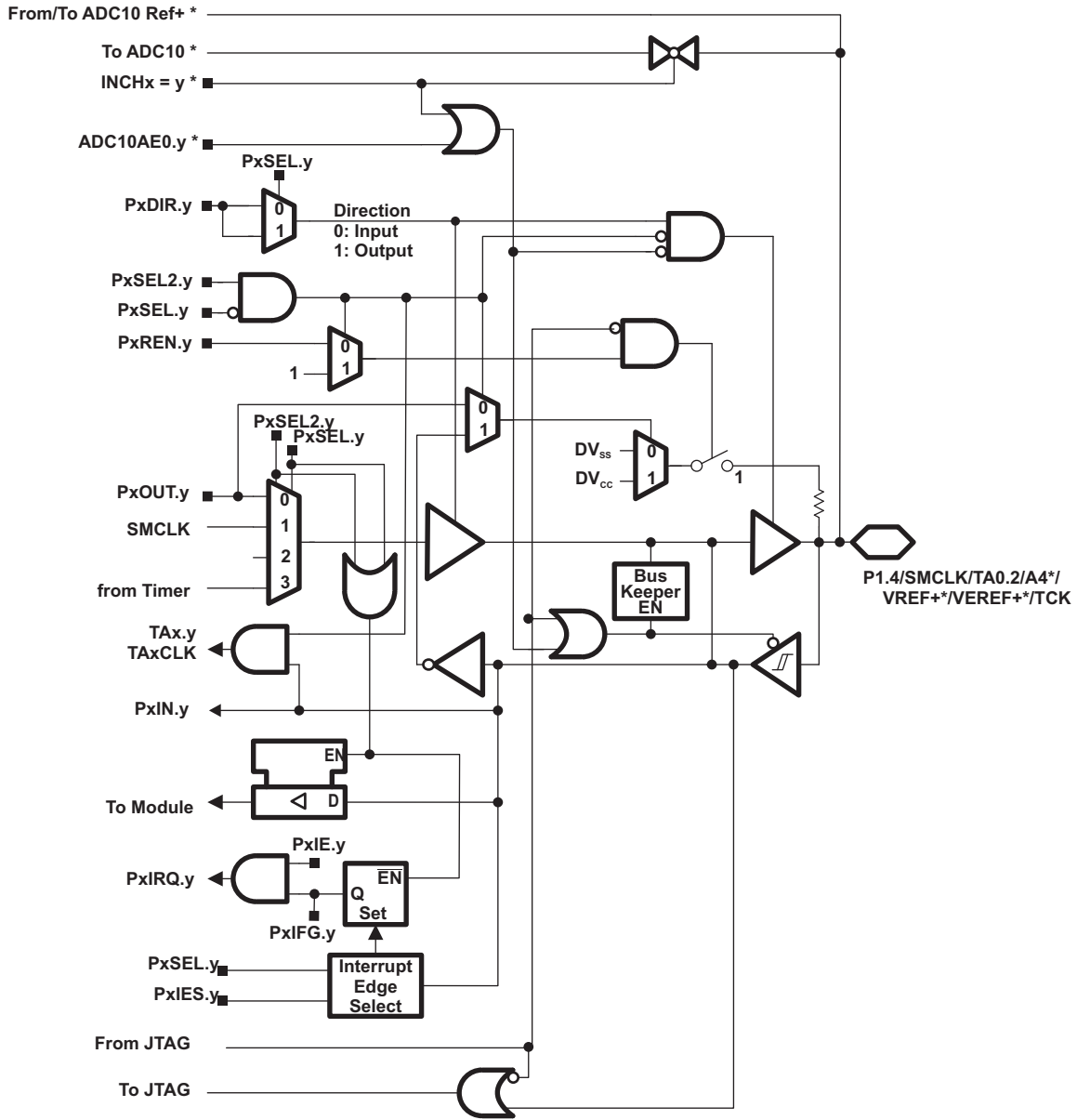
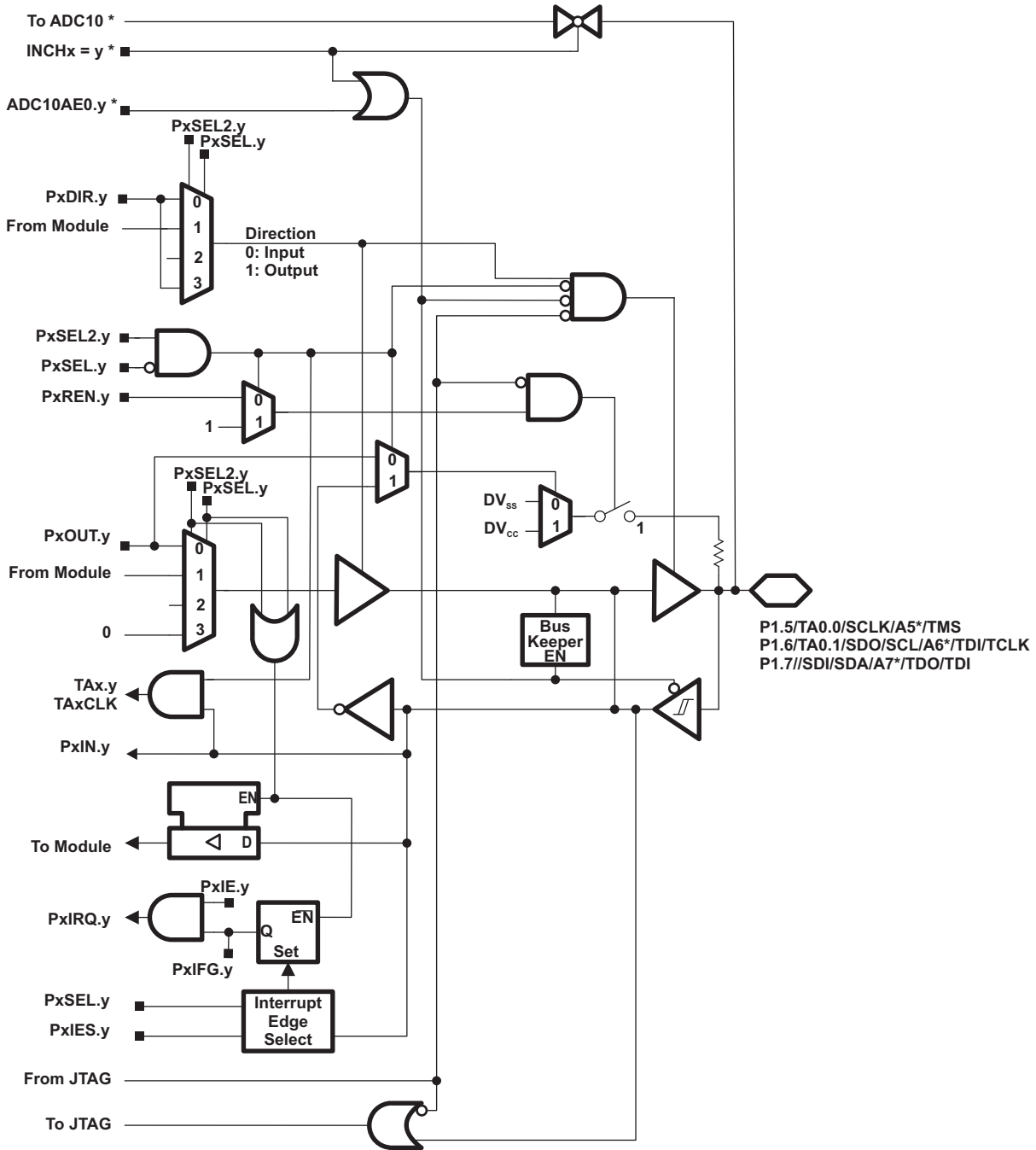

**Table 17. Port P1 (P1.4) Pin Functions**

PIN NAME (P1.x)	x	FUNCTION	CONTROL BITS / SIGNALS <sup>(1)</sup>				
			P1DIR.x	P1SEL.x	P1SEL2.x	ADC10AE.x (INCH.x=1)	JTAG Mode
P1.4/ SMCLK/ TA0.2/ VREF+/ VEREF+/ A4/ TCK/ Pin Osc	4	P1.x (I/O)	I: 0; O: 1	0	0	0	0
SMCLK		1	1	0	0	0	
TA0.2		1	1	1	0	0	
TA0.CCI2A		0	1	1	0	0	
VREF+		X	X	X	1	0	
VEREF+		X	X	X	1	0	
A4		X	X	X	1 (y = 4)	0	
TCK		X	X	X	0	1	
Capacitive sensing	X	0	1	0	0		

(1) X = don't care

Port P1 Pin Schematic: P1.5 to P1.7, Input/Output With Schmitt Trigger



\* Note: MSP430G2x32 devices only. MSP430G2x02 devices have no ADC10.

**Table 18. Port P1 (P1.5 to P1.7) Pin Functions**

PIN NAME (P1.x)	x	FUNCTION	CONTROL BITS / SIGNALS <sup>(1)</sup>					ADC10AE.x (INCH.x=1)
			P1DIR.x	P1SEL.x	P1SEL2.x	USIP.x	JTAG Mode	
P1.5/ TA0.0/ SCLK/ A5/ TMS/ Pin Osc	5	P1.x (I/O)	I: 0; O: 1	0	0	0	0	0
TA0.0		1	1	0	0	0	0	
SPI mode		from USI	1	0	1	0	0	
A5		X	X	X	0	0	1 (y = 5)	
TMS		X	X	X	0	1	0	
Capacitive sensing		X	0	1	0	0	0	
P1.6/ TA0.1/ SDO/ SCL/ A6/ TDI/TCLK/ Pin Osc	6	P1.x (I/O)	I: 0; O: 1	0	0	0	0	0
TA0.1		1	1	0	0	0	0	
SPI mode		from USI	1	0	!	0	0	
I2C mode		from USI	1	0	!	0	0	
A6		X	X	X	0	0	1 (y = 6)	
TDI/TCLK		X	X	X	0	1	0	
Capacitive sensing	X	0	1	0	0	0		
P1.7/ SDI/ SDA/ A7/ TDO/TDI/ Pin Osc	7	P1.x (I/O)	I: 0; O: 1	0	0	0	0	0
SPI mode		from USI	1	0	1	0	0	
SPI mode		from USI	1	0	1	0	0	
A7		X	X	X	0	0	1 (y = 7)	
TDO/TDI		X	X	X	0	1	0	
Capacitive sensing		X	0	1	0	0	0	

(1) X = don't care



Port P2 Pin Schematic: P2.0 to P2.5, Input/Output With Schmitt Trigger

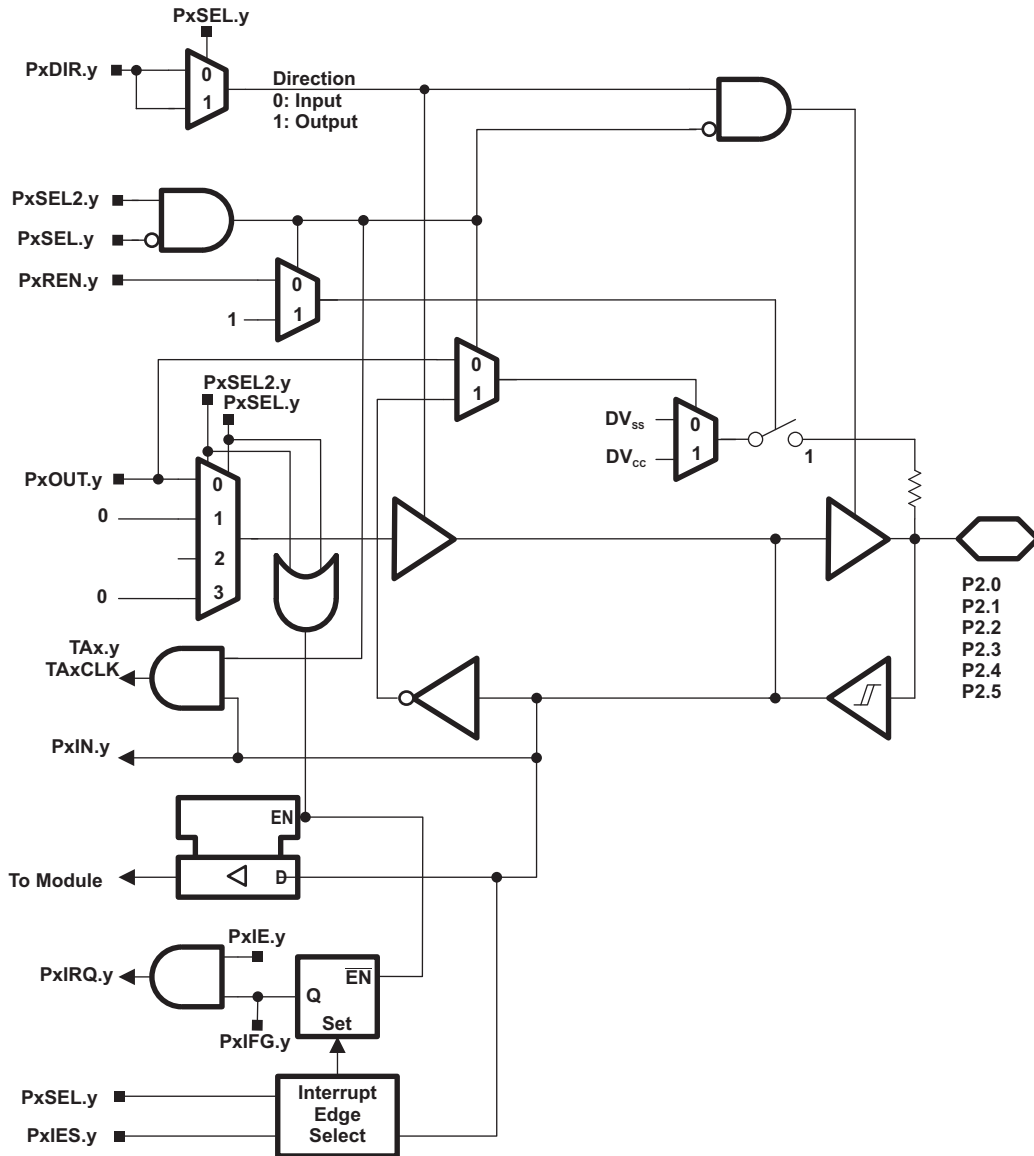

**Table 19. Port P2 (P2.0 to P2.5) Pin Functions**

PIN NAME (P2.x)	x	FUNCTION	CONTROL BITS / SIGNALS <sup>(1)</sup>		
			P2DIR.x	P2SEL.x	P2SEL2.x
P2.0/ Pin Osc	0	P2.x (I/O)	I: 0; O: 1	0	0
		Capacitive sensing	X	0	1
P2.1/ Pin Osc	1	P2.x (I/O)	I: 0; O: 1	0	0
		Capacitive sensing	X	0	1
P2.2/ Pin Osc	2	P2.x (I/O)	I: 0; O: 1	0	0
		Capacitive sensing	X	0	1
P2.3/ Pin Osc	3	P2.x (I/O)	I: 0; O: 1	0	0
		Capacitive sensing	X	0	1
P2.4/ Pin Osc	4	P2.x (I/O)	I: 0; O: 1	0	0
		Capacitive sensing	X	0	1
P2.5/ Pin Osc	5	P2.x (I/O)	I: 0; O: 1	0	0
		Capacitive sensing	X	0	1

(1) X = don't care

Port P2 Pin Schematic: P2.6, Input/Output With Schmitt Trigger

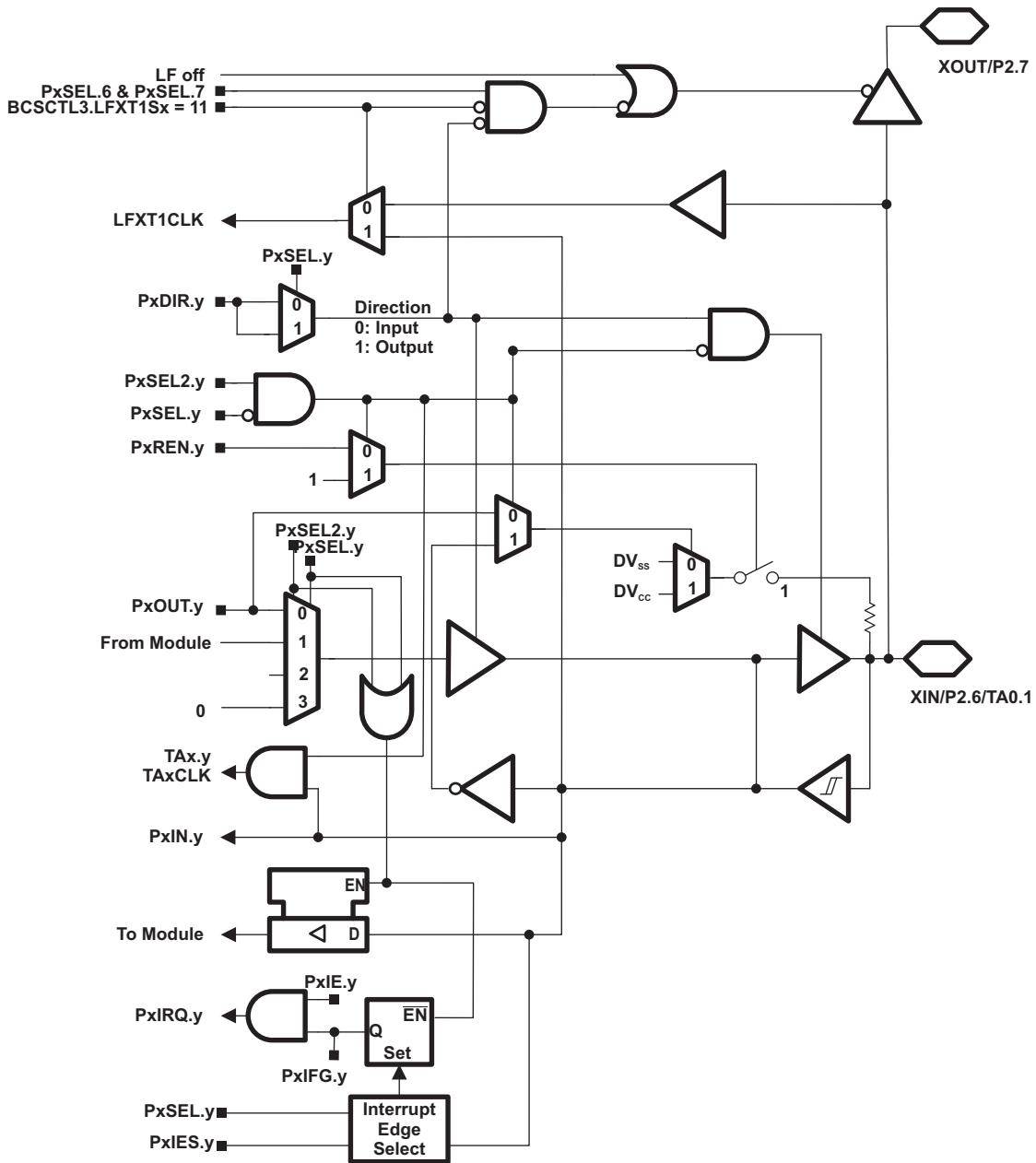

Table 20. Port P2 (P2.6) Pin Functions

PIN NAME (P2.x)	x	FUNCTION	CONTROL BITS / SIGNALS <sup>(1)</sup>		
			P2DIR.x	P2SEL.6 P2SEL.7	P2SEL2.6 P2SEL2.7
XIN/	6	XIN	0	1 1	0 0
P2.6/		P2.x (I/O)	I: 0; O: 1	0 X	0 0
TA0.1/		Timer0_A3.TA1	1	1 0	0 0
Pin Osc		Capacitive sensing	X	0 X	1 X

(1) X = don't care

Port P2 Pin Schematic: P2.7, Input/Output With Schmitt Trigger

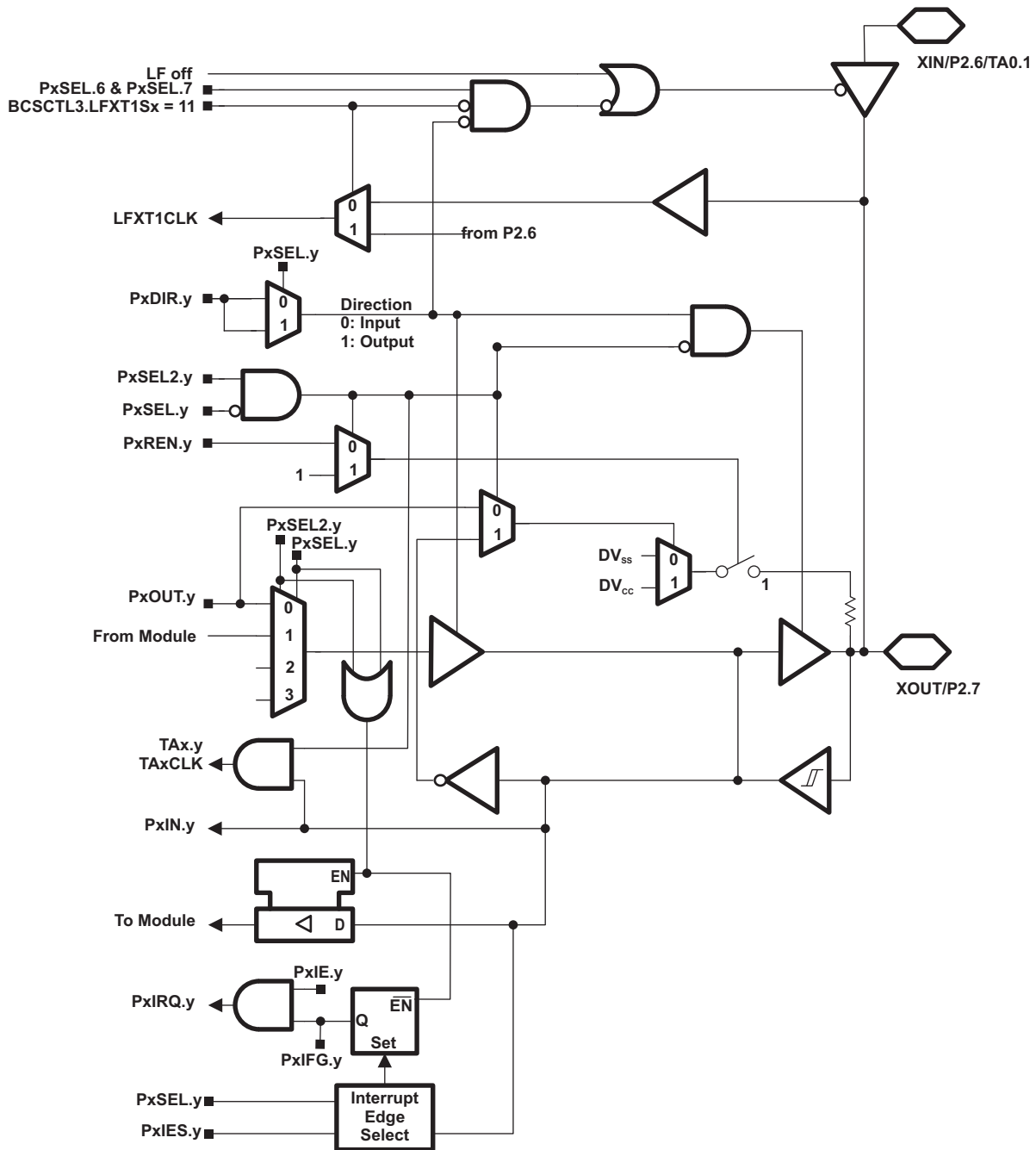

Table 21. Port P2 (P2.7) Pin Functions

PIN NAME (P2.x)	x	FUNCTION	CONTROL BITS / SIGNALS <sup>(1)</sup>		
			P2DIR.x	P2SEL.6 P2SEL.7	P2SEL2.6 P2SEL2.7
XOUT/		XOUT	X	1 1	0 0
P2.7/	7	P2.x (I/O)	I: 0; O: 1	X 0	0 0
Pin Osc		Capacitive sensing	X	X 0	X 1

(1) X = don't care

**PACKAGING INFORMATION**

Orderable Device	Status (1)	Package Type	Package Drawing	Pins	Package Qty	Eco Plan (2)	Lead finish/ Ball material (6)	MSL Peak Temp (3)	Op Temp (°C)	Device Marking (4/5)	Samples
MSP430G2302IPW1EP	ACTIVE	TSSOP	PW	14	90	RoHS & Green	NIPDAU	Level-1-260C-UNLIM	-40 to 85	G2302EP	<a href="#">Samples</a>
MSP430G2302IPW1REP	ACTIVE	TSSOP	PW	14	2000	RoHS & Green	NIPDAU	Level-1-260C-UNLIM	-40 to 85	G2302EP	<a href="#">Samples</a>
V62/12623-01XE	ACTIVE	TSSOP	PW	14	2000	RoHS & Green	NIPDAU	Level-1-260C-UNLIM	-40 to 85	G2302EP	<a href="#">Samples</a>
V62/12623-01XE-T	ACTIVE	TSSOP	PW	14	90	RoHS & Green	NIPDAU	Level-1-260C-UNLIM	-40 to 85	G2302EP	<a href="#">Samples</a>

(1) The marketing status values are defined as follows:

**ACTIVE:** Product device recommended for new designs.

**LIFEBUY:** TI has announced that the device will be discontinued, and a lifetime-buy period is in effect.

**NRND:** Not recommended for new designs. Device is in production to support existing customers, but TI does not recommend using this part in a new design.

**PREVIEW:** Device has been announced but is not in production. Samples may or may not be available.

**OBSELETE:** TI has discontinued the production of the device.

(2) **RoHS:** TI defines "RoHS" to mean semiconductor products that are compliant with the current EU RoHS requirements for all 10 RoHS substances, including the requirement that RoHS substance do not exceed 0.1% by weight in homogeneous materials. Where designed to be soldered at high temperatures, "RoHS" products are suitable for use in specified lead-free processes. TI may reference these types of products as "Pb-Free".

**RoHS Exempt:** TI defines "RoHS Exempt" to mean products that contain lead but are compliant with EU RoHS pursuant to a specific EU RoHS exemption.

**Green:** TI defines "Green" to mean the content of Chlorine (Cl) and Bromine (Br) based flame retardants meet JS709B low halogen requirements of <=1000ppm threshold. Antimony trioxide based flame retardants must also meet the <=1000ppm threshold requirement.

(3) MSL, Peak Temp. - The Moisture Sensitivity Level rating according to the JEDEC industry standard classifications, and peak solder temperature.

(4) There may be additional marking, which relates to the logo, the lot trace code information, or the environmental category on the device.

(5) Multiple Device Markings will be inside parentheses. Only one Device Marking contained in parentheses and separated by a "-" will appear on a device. If a line is indented then it is a continuation of the previous line and the two combined represent the entire Device Marking for that device.

(6) Lead finish/Ball material - Orderable Devices may have multiple material finish options. Finish options are separated by a vertical ruled line. Lead finish/Ball material values may wrap to two lines if the finish value exceeds the maximum column width.

**Important Information and Disclaimer:**The information provided on this page represents TI's knowledge and belief as of the date that it is provided. TI bases its knowledge and belief on information provided by third parties, and makes no representation or warranty as to the accuracy of such information. Efforts are underway to better integrate information from third parties. TI has taken and

continues to take reasonable steps to provide representative and accurate information but may not have conducted destructive testing or chemical analysis on incoming materials and chemicals. TI and TI suppliers consider certain information to be proprietary, and thus CAS numbers and other limited information may not be available for release.

In no event shall TI's liability arising out of such information exceed the total purchase price of the TI part(s) at issue in this document sold by TI to Customer on an annual basis.

**OTHER QUALIFIED VERSIONS OF MSP430G2302-EP :**

- Catalog: [MSP430G2302](#)

NOTE: Qualified Version Definitions:

- Catalog - TI's standard catalog product

**TAPE AND REEL INFORMATION**

**QUADRANT ASSIGNMENTS FOR PIN 1 ORIENTATION IN TAPE**

\*All dimensions are nominal

Device	Package Type	Package Drawing	Pins	SPQ	Reel Diameter (mm)	Reel Width W1 (mm)	A0 (mm)	B0 (mm)	K0 (mm)	P1 (mm)	W (mm)	Pin1 Quadrant
MSP430G2302IPW1REP	TSSOP	PW	14	2000	330.0	12.4	6.9	5.6	1.6	8.0	12.0	Q1

**TAPE AND REEL BOX DIMENSIONS**

\*All dimensions are nominal

Device	Package Type	Package Drawing	Pins	SPQ	Length (mm)	Width (mm)	Height (mm)
MSP430G2302IPW1REP	TSSOP	PW	14	2000	356.0	356.0	35.0



**TUBE**

\*All dimensions are nominal

Device	Package Name	Package Type	Pins	SPQ	L (mm)	W (mm)	T (μm)	B (mm)
MSP430G2302IPW1EP	PW	TSSOP	14	90	530	10.2	3600	3.5
V62/12623-01XE-T	PW	TSSOP	14	90	530	10.2	3600	3.5

PW (R-PDSO-G14)

PLASTIC SMALL OUTLINE



- NOTES:
- A. All linear dimensions are in millimeters. Dimensioning and tolerancing per ASME Y14.5M-1994.
  - B. This drawing is subject to change without notice.
  - C. Body length does not include mold flash, protrusions, or gate burrs. Mold flash, protrusions, or gate burrs shall not exceed 0,15 each side.
  - D. Body width does not include interlead flash. Interlead flash shall not exceed 0,25 each side.
  - E. Falls within JEDEC MO-153

PW (R-PDSO-G14)

PLASTIC SMALL OUTLINE



4211284-2/G 08/15

- NOTES:
- All linear dimensions are in millimeters.
  - This drawing is subject to change without notice.
  - Publication IPC-7351 is recommended for alternate designs.
  - Laser cutting apertures with trapezoidal walls and also rounding corners will offer better paste release. Customers should contact their board assembly site for stencil design recommendations. Refer to IPC-7525 for other stencil recommendations.
  - Customers should contact their board fabrication site for solder mask tolerances between and around signal pads.

## 重要声明和免责声明

TI“按原样”提供技术和可靠性数据（包括数据表）、设计资源（包括参考设计）、应用或其他设计建议、网络工具、安全信息和其他资源，不保证没有瑕疵且不做任何明示或暗示的担保，包括但不限于对适销性、某特定用途方面的适用性或不侵犯任何第三方知识产权的暗示担保。

这些资源可供使用 TI 产品进行设计的熟练开发人员使用。您将自行承担以下全部责任：(1) 针对您的应用选择合适的 TI 产品，(2) 设计、验证并测试您的应用，(3) 确保您的应用满足相应标准以及任何其他功能安全、信息安全、监管或其他要求。

这些资源如有变更，恕不另行通知。TI 授权您仅可将这些资源用于研发本资源所述的 TI 产品的应用。严禁对这些资源进行其他复制或展示。您无权使用任何其他 TI 知识产权或任何第三方知识产权。您应全额赔偿因在这些资源的使用中对 TI 及其代表造成的任何索赔、损害、成本、损失和债务，TI 对此概不负责。

TI 提供的产品受 [TI 的销售条款](#) 或 [ti.com](#) 上其他适用条款/TI 产品随附的其他适用条款的约束。TI 提供这些资源并不会扩展或以其他方式更改 TI 针对 TI 产品发布的适用的担保或担保免责声明。

TI 反对并拒绝您可能提出的任何其他或不同的条款。

邮寄地址：Texas Instruments, Post Office Box 655303, Dallas, Texas 75265

Copyright © 2022，德州仪器 (TI) 公司