

具有 RSSI 的 11.3 Gbps 限幅互阻抗放大器

查询样品: [ONET8521T](#)

特性

- **9 GHz** 带宽
- **2.4 k Ω** 差分小信号互阻抗
- **-20dBm** 敏感度
- **0.95 μA_{RMS}** 输入参考噪声
- **2.5 mA_{PP}** 输入过载电流
- 接收信号强度指示 (**RSSI**)
- **90 mW** 典型功率耗散
- 支持片载 **50 Ω** 背向端接的 **CML** 数据输出
- 片载电源滤波器电容器
- **3.3 V** 单电源

- 模具尺寸: **870 μm \times 1036 μm**

应用

- **10G** 以太网
- **8G** 和 **10G** 光纤通道
- **10G EPON**
- **SONET OC-192**
- **6G CPRI** 和 **OBSAI**
- **PIN** 预放大器接收器
- **APD** 预放大器接收器

说明

ONET8521T 是一款高速限幅互阻抗放大器，适用于数据传输速率高达 11.3 Gbps 的光电接收器。它特有低输入参考噪声、9 GHz 带宽、2.4 k Ω 小信号互阻抗以及接收信号强度指示 (RSSI)。

ONET8541T 采用模具成型方式，包括一个片载 V_{CC} 旁路电容器并且非常适合封装在 TO 罐内。

ONET8521T 要求 3.3 V \pm 10% 单电源供电，其高能效设计使其典型耗散少于 90mW。该器件可在 -40°C 至 100°C (IC 背面) 环境下平稳工作。



Please be aware that an important notice concerning availability, standard warranty, and use in critical applications of Texas Instruments semiconductor products and disclaimers thereto appears at the end of this data sheet.



This integrated circuit can be damaged by ESD. Texas Instruments recommends that all integrated circuits be handled with appropriate precautions. Failure to observe proper handling and installation procedures can cause damage.

ESD damage can range from subtle performance degradation to complete device failure. Precision integrated circuits may be more susceptible to damage because very small parametric changes could cause the device not to meet its published specifications.

BLOCK DIAGRAM

A simplified block diagram of the ONET8521T is shown in Figure 1.

The ONET8521T consists of the signal path, supply filters, a control block for dc input bias, automatic gain control (AGC) and received signal strength indication (RSSI). The RSSI provides the bias for the TIA stage and the control for the AGC.

The signal path consists of a transimpedance amplifier stage, a voltage amplifier, and a CML output buffer. The on-chip filter circuit provides a filtered V_{CC} for the PIN photodiode and for the transimpedance amplifier.

The dc input bias circuit and automatic gain control use internal low pass filters to cancel the dc current on the input and to adjust the transimpedance amplifier gain. Furthermore, circuitry is provided to monitor the received signal strength.

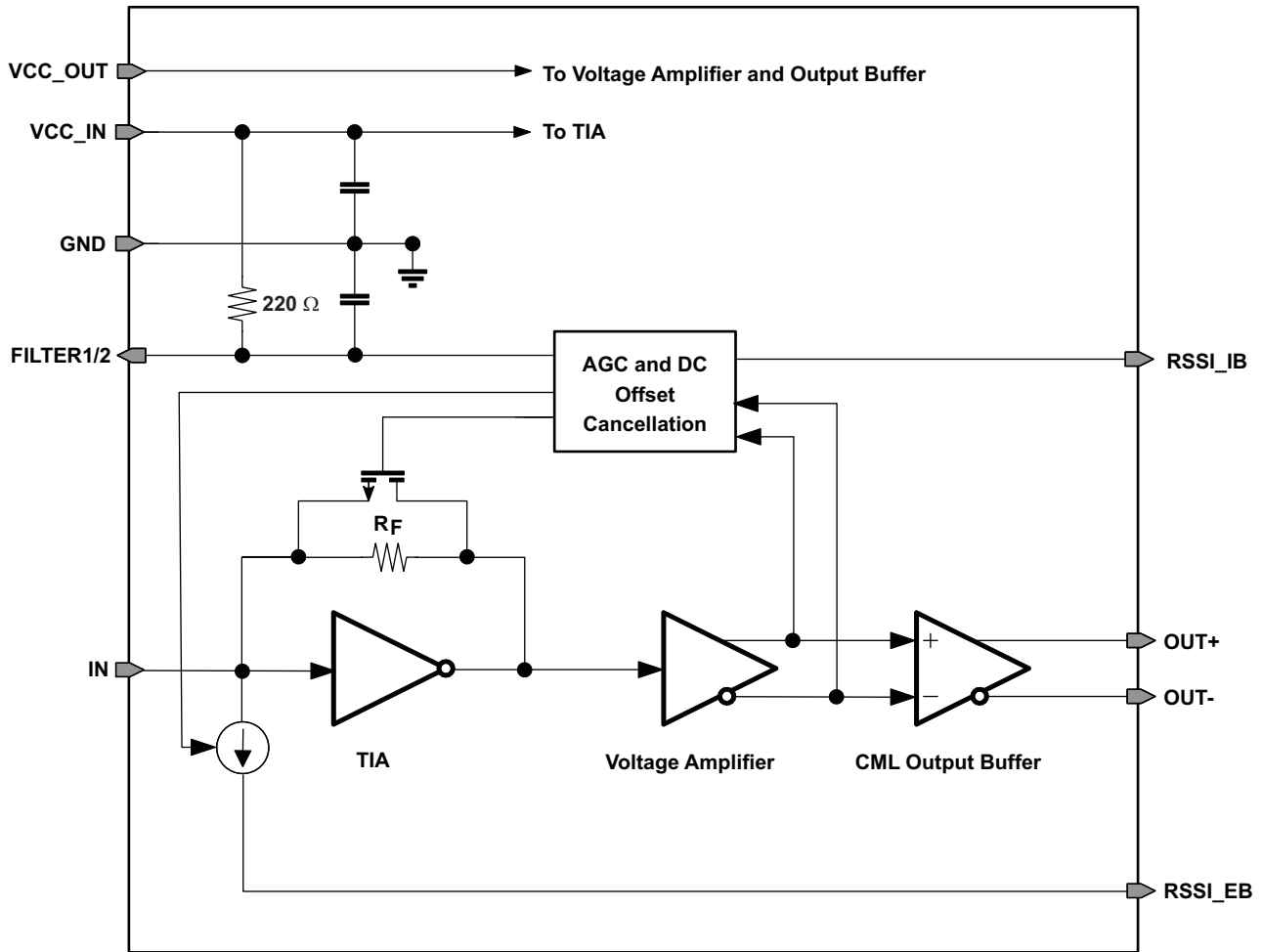

Figure 1. Simplified Block Diagram of the ONET8521T

BOND PAD ASSIGNMENT

The ONET8521T is available in die form. The locations of the bondpads are shown in Figure 2.

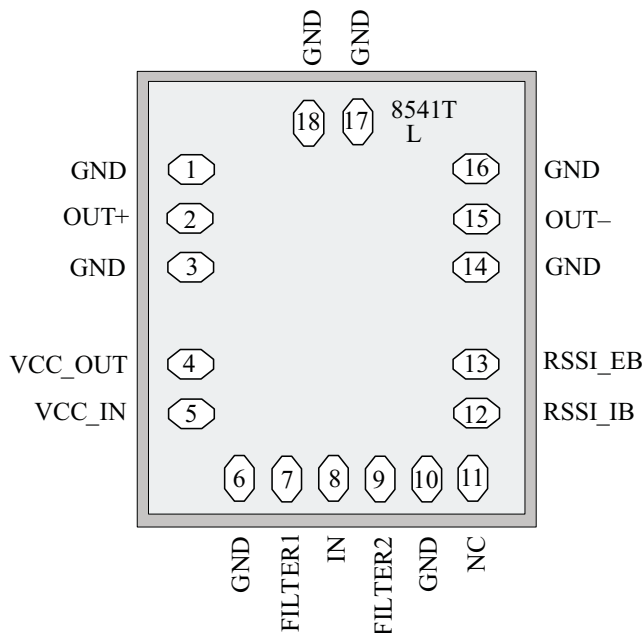

Figure 2. Bond Pad Assignment of ONET8521T

PIN FUNCTIONS

| PIN | | TYPE | DESCRIPTION |
|---------|----------------------------|---------------|--|
| NAME | NO. | | |
| GND | 1, 3, 6, 10 14, 16 – 18 | Supply | Circuit ground. All GND pads are connected on die. Bonding all pads is optional; however, for optimum performance a good ground connection is mandatory. |
| OUT+ | 2 | Analog output | Non-inverted CML data output. On-chip 50Ω back-terminated to V _{CC} . |
| VCC_OUT | 4 | Supply | 2.97V–3.63V supply voltage for the voltage and CML amplifiers. |
| VCC_IN | 5 | Supply | 2.97V–3.63V supply voltage for input TIA stage. |
| FILTER | 7, 9 | Analog | Bias voltage for photodiode cathode. These pads are internally connected to an 220Ω resistor to V _{CC} and a filter capacitor to ground (GND). |
| IN | 8 | Analog input | Data input to TIA (photodiode anode). |
| NC | 11 | No Connect | Do not connect |
| RSSI_IB | 12 | Analog output | Analog output current proportional to the input data amplitude. Indicates the strength of the received signal (RSSI) if the photo diode is biased from the TIA. Connected to an external resistor to ground (GND). For proper operation, ensure that the voltage at the RSSI pad does not exceed V _{CC} – 0.65V. If the RSSI feature is not used this pad should be left open. |
| RSSI_EB | 13 | Analog output | Optional use when operated with external PD bias (e.g. APD). Analog output current proportional to the input data amplitude. Indicates the strength of the received signal (RSSI). Connected to an external resistor to ground (GND). For proper operation, ensure that the voltage at the RSSI pad does not exceed V _{CC} – 0.65V. If the RSSI feature is not used this pad should be left open. |
| OUT– | 15 | Analog output | Inverted CML data output. On-chip 50Ω back-terminated to V _{CC} . |

ABSOLUTE MAXIMUM RATINGS

over operating free-air temperature range (unless otherwise noted)⁽¹⁾

| | | MIN | MAX | UNIT |
|---|--|------|-----|----------|
| V _{CC_IN} , V _{CC_OUT} | Supply voltage ⁽²⁾ | -0.3 | 4.0 | V |
| V _{FILTER1} , V _{FILTER2} , V _{OUT+} , V _{OUT-} , V _{RSSI_IB} , V _{RSSI_EB} | Voltage at FILTER1, FILTER2, OUT+, OUT-, RSSI_IB, RSSI_EB ⁽²⁾ | -0.3 | 4.0 | V |
| I _{IN} | Current into IN | -0.7 | 3.5 | mA |
| I _{FILTER} | Current into FILTER1, FILTER2 | -8 | 8 | mA |
| I _{OUT+} , I _{OUT-} | Continuous current at outputs | -8 | 8 | mA |
| ESD | ESD rating at all pins except input IN | 2 | | kV (HBM) |
| | ESD rating at input IN | 0.5 | | kV(HBM) |
| T _{J,max} | Maximum junction temperature | | 125 | °C |

- (1) Stresses beyond those listed under *absolute maximum ratings* may cause permanent damage to the device. These are stress ratings only and functional operation of the device at these or any other conditions beyond those indicated under *recommended operating conditions* is not implied. Exposure to absolute-maximum-rated conditions for extended periods may affect device reliability.
- (2) All voltage values are with respect to network ground terminal.

RECOMMENDED OPERATING CONDITIONS

| PARAMETER | | CONDITIONS | MIN | NOM | MAX | UNIT |
|--|--|------------|------|-----|--------------------|------|
| V _{CC} | Supply voltage | | 2.97 | 3.3 | 3.63 | V |
| T _A | Operating backside die temperature | | -40 | | 100 ⁽¹⁾ | °C |
| L _{FILTER} , L _{IN} | Wire-bond inductor at pins FILTER and IN | | | 0.3 | 0.5 | nH |
| C _{PD} | Photodiode capacitance | | | 0.2 | | pF |

- (1) 105°C maximum junction temperature

DC ELECTRICAL CHARACTERISTICS

over recommended operating conditions (unless otherwise noted). Typical values are at V_{CC} = 3.3 V and T_A = 25°C

| PARAMETER | TEST CONDITIONS | MIN | TYP | MAX | UNIT |
|---------------------|---|------|------|-------------------|------|
| V _{CC} | Supply voltage | 2.97 | 3.3 | 3.63 | V |
| I _{VCC} | Input current i _{IN} < 1000 μA _{PP} | | 27 | 40 ⁽¹⁾ | mA |
| | Input current i _{IN} < 2500 μA _{PP} | | | 45 ⁽¹⁾ | |
| V _{IN} | Input bias voltage | 0.75 | 0.85 | 0.98 | V |
| R _{OUT} | Output resistance | 40 | 50 | 60 | Ω |
| R _{FILTER} | Photodiode filter resistance | | 220 | | Ω |

- (1) Including RSSI current

AC ELECTRICAL CHARACTERISTICS

over recommended operating conditions (unless otherwise noted). Typical values are at $V_{CC} = +3.3\text{ V}$ and $T_A = 25^\circ\text{C}$

| PARAMETER | | TEST CONDITIONS | MIN | TYP | MAX | UNIT |
|-----------------|--|--|------|------|------|------------------|
| Z_{21} | Small signal transimpedance | Differential output; Input current $i_{IN} = 20\ \mu\text{A}_{PP}$ | 1500 | 2400 | | Ω |
| $f_{HSS,3dB}$ | Small signal bandwidth | $i_{IN} = 16\ \mu\text{A}_{PP}$ ⁽¹⁾ | 7 | 9 | | GHz |
| $f_{L,3dB}$ | Low frequency –3 dB bandwidth | $16\ \mu\text{A} < i_{IN} < 2000\ \mu\text{A}_{PP}$ | | 30 | 100 | kHz |
| $i_{N,IN}$ | Input referred RMS noise | 10 GHz bandwidth ⁽²⁾ | | 0.95 | 1.4 | μA |
| S_{US} | Unstressed sensitivity | 10.3125 Gbps, PRBS31 pattern, 1310 nm, BER 10^{-12} | | –20 | | dBm |
| DJ | Deterministic jitter | $25\ \mu\text{A}_{PP} < i_{IN} < 500\ \mu\text{A}_{PP}$ (10.3125 Gbps, K28.5 pattern) | | 6 | 12 | pS_{PP} |
| | | $500\ \mu\text{A}_{PP} < i_{IN} < 2000\ \mu\text{A}_{PP}$ (10.3125 Gbps, K28.5 pattern) | | 6 | 14 | |
| DJ_{OL} | Overload deterministic jitter | $2000\ \mu\text{A}_{PP} < i_{IN} < 2500\ \mu\text{A}_{PP}$ (10.3125 Gbps, K28.5 pattern) | | 7 | 16 | pS_{PP} |
| $V_{OUT,D,MAX}$ | Maximum differential output voltage | Input current $i_{IN} = 500\ \mu\text{A}_{PP}$ | 180 | 300 | 420 | mV_{PP} |
| A_{RSSI_IB} | RSSI gain internal bias | Resistive load to GND ⁽³⁾ | 0.48 | 0.5 | 0.52 | A/A |
| | RSSI internal bias output offset current (no light) ⁽⁴⁾ | | 2 | 7 | 16 | μA |
| A_{RSSI_EB} | RSSI gain external bias | Resistive load to GND ⁽³⁾ | 0.43 | | 0.6 | A/A |
| | RSSI external bias output offset current (no light) | | | 25 | | μA |
| PSNR | Power supply noise rejection | $F < 10\ \text{MHz}$ ⁽⁵⁾ , Supply filtering according to SFF8431 | | –15 | | dB |

- (1) The small signal bandwidth is specified over process corners, temperature, and supply voltage variation. The assumed photodiode capacitance is 0.2 pF and the bond-wire inductance is 0.3 nH. The small signal bandwidth strongly depends on environmental parasitics. Careful attention to layout parasitics and external components is necessary to achieve optimal performance.
- (2) Input referred RMS noise is (RMS output noise)/ (gain at 100 MHz).
- (3) The RSSI output is a current output, which requires a resistive load to ground (GND). The voltage gain can be adjusted for the intended application by choosing the external resistor; however, for proper operation, ensure that the voltage at RSSI does not exceed $V_{CC} - 0.65\text{V}$.
- (4) Offset is added to improve accuracy below 5 μA . When measured without input current (no light) the offset can be subtracted as a constant offset from RSSI measurements.
- (5) PSNR is the differential output amplitude divided by the voltage ripple on supply; no input current at IN.

DETAILED DESCRIPTION

SIGNAL PATH

The first stage of the signal path is a transimpedance amplifier which converts the photodiode current into a voltage. If the input signal current exceeds a certain value, the transimpedance gain is reduced by means of a nonlinear AGC circuit to limit the signal amplitude.

The second stage is a limiting voltage amplifier that provides additional limiting gain and converts the single ended input voltage into a differential data signal. The output stage provides CML outputs with an on-chip 50Ω back-termination to V_{CC} .

FILTER CIRCUITRY

The FILTER pins provide a filtered V_{CC} for a PIN photodiode bias. The on-chip low pass filter for the photodiode is implemented using a filter resistor of 220Ω and a capacitor. The corresponding corner frequency is below 5MHz. The supply voltages for the transimpedance amplifier are filtered by means of on-chip capacitors, thus avoiding the necessity to use an external supply filter capacitor. The input stage has a separate V_{CC} supply (V_{CC_IN}) which is not connected on chip to the supply of the limiting and CML stages (V_{CC_OUT}).

AGC AND RSSI

The voltage drop across the internal photodiode supply-filter resistor is monitored by the bias and RSSI control circuit block in the case where a PIN diode is biased using the FILTER pins.

If the dc input current exceeds a certain level then it is partially cancelled by means of a controlled current source. This keeps the transimpedance amplifier stage within sufficient operating limits for optimum performance.

The automatic gain control circuitry adjusts the voltage gain of the AGC amplifier to ensure limiting behavior of the complete amplifier.

Finally this circuit block senses the current through the filter resistor and generates a mirrored current that is proportional to the input signal strength. The mirrored current is available at the RSSI_IB output and can be sunk to ground (GND) using an external resistor. For proper operation, ensure that the voltage at the RSSI_IB pad does not exceed $V_{CC} - 0.65V$.

If an APD or PIN photodiode is used with an external bias then the RSSI_EB pin should be used. However, for greater accuracy under external photo diode biasing conditions, it is recommended to derive the RSSI from the external bias circuitry.

TYPICAL OPERATION CHARACTERISTICS

Typical operating condition is at $V_{CC} = 3.3\text{ V}$ and $T_A = 25^\circ\text{C}$ (unless otherwise noted)

**TRANSIMPEDANCE
vs
INPUT CURRENT**

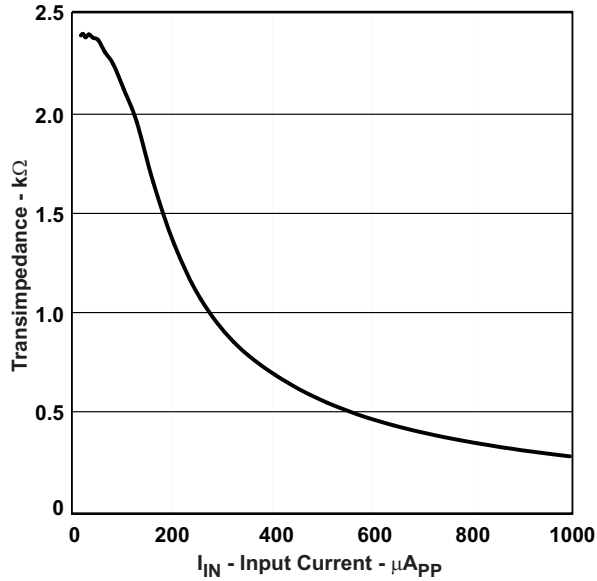

Figure 3.

**SMALL SIGNAL TRANSIMPEDANCE
vs
AMBIENT TEMPERATURE**

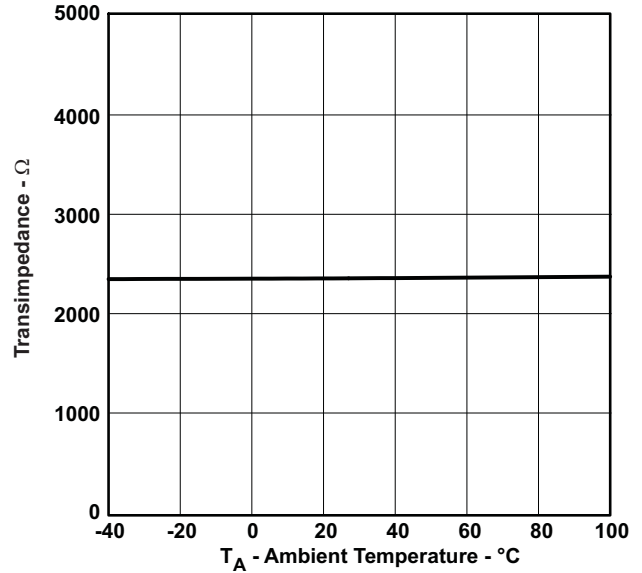

Figure 4.

**SMALL SIGNAL TRANSFER
CHARACTERISTICS**

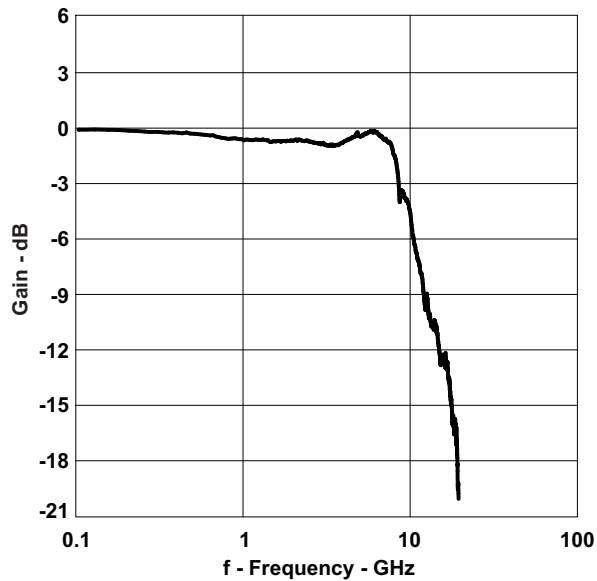

Figure 5.

**SMALL SIGNAL BANDWIDTH
vs
AMBIENT TEMPERATURE**

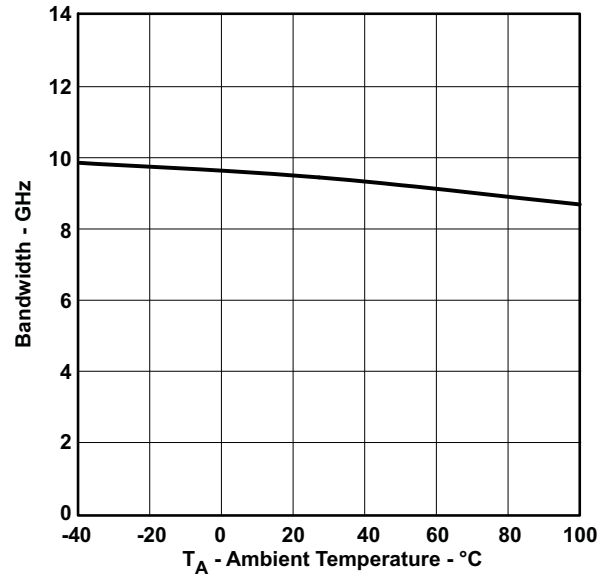

Figure 6.

TYPICAL OPERATION CHARACTERISTICS (continued)

Typical operating condition is at $V_{CC} = 3.3\text{ V}$ and $T_A = 25^\circ\text{C}$ (unless otherwise noted)

**OUTPUT VOLTAGE
vs
INPUT CURRENT**

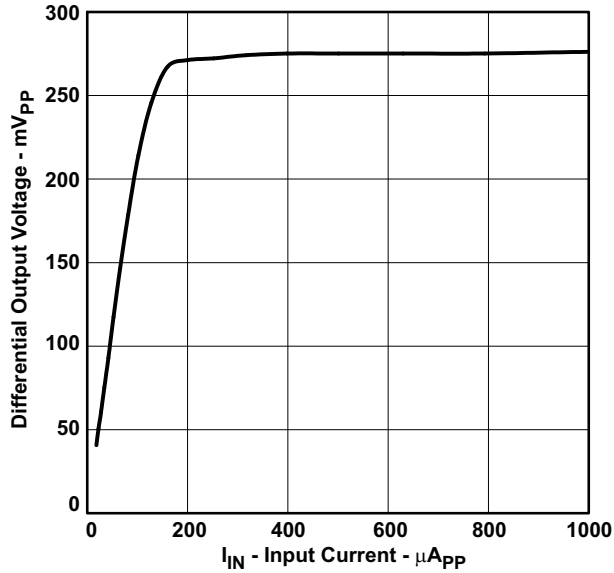

Figure 7.

**DETERMINISTIC JITTER
vs
INPUT CURRENT**

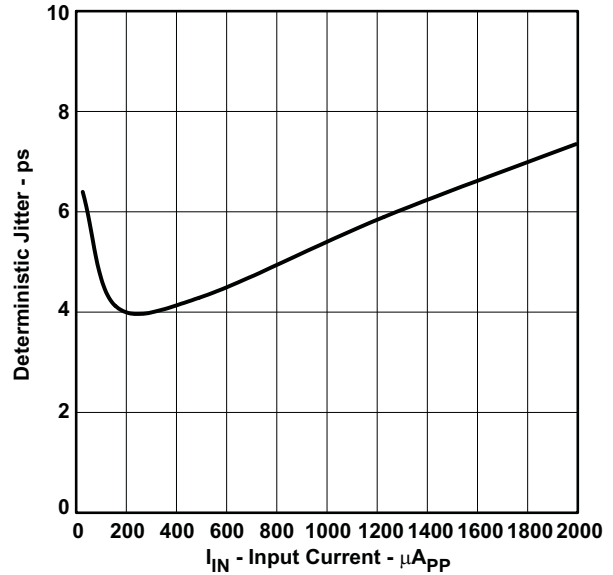

Figure 8.

**INPUT REFERRED NOISE
vs
TEMPERATURE**

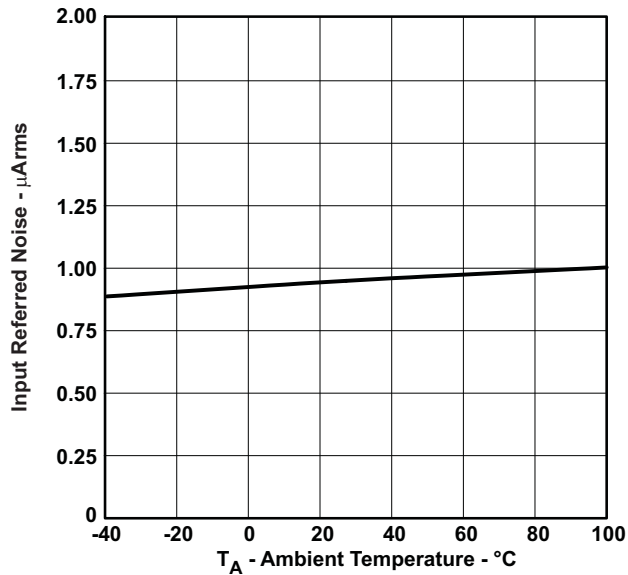

Figure 9.

**RSSI_IB OUTPUT CURRENT
vs
AVERAGE INPUT CURRENT**

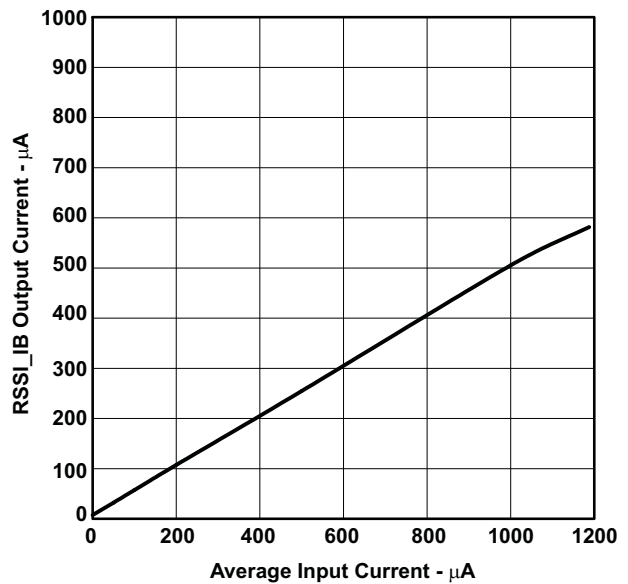
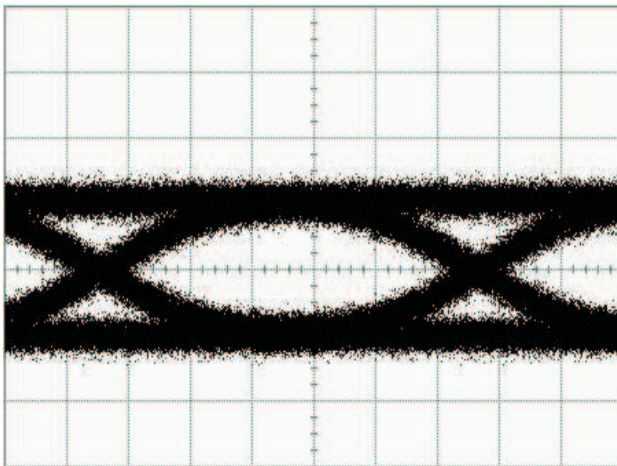

Figure 10.

TYPICAL OPERATION CHARACTERISTICS (continued)

Typical operating condition is at $V_{CC} = 3.3\text{ V}$ and $T_A = 25^\circ\text{C}$ (unless otherwise noted)

**OUTPUT EYE-DIAGRAM AT 10.3 GBPS
AND $20\ \mu\text{A}_{PP}$ INPUT CURRENT**



25 mV/div 20 ps/div

Figure 11.

**OUTPUT EYE-DIAGRAM AT 10.3 GBPS
AND $100\ \mu\text{A}_{PP}$ INPUT CURRENT**

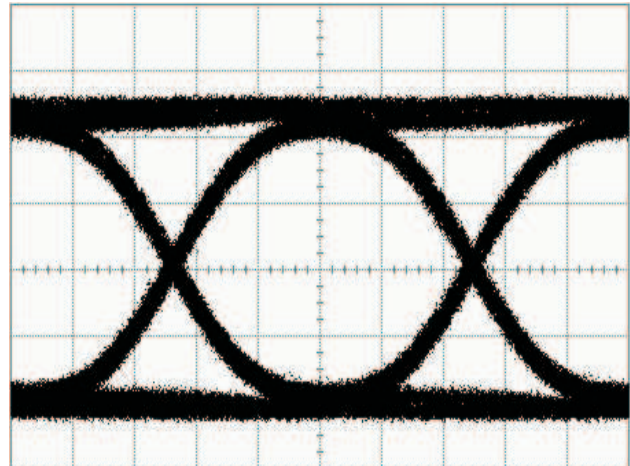

50 mV/div 20 ps/div

Figure 12.

**OUTPUT EYE-DIAGRAM AT 10.3 GBPS
AND $500\ \mu\text{A}_{PP}$ INPUT CURRENT**

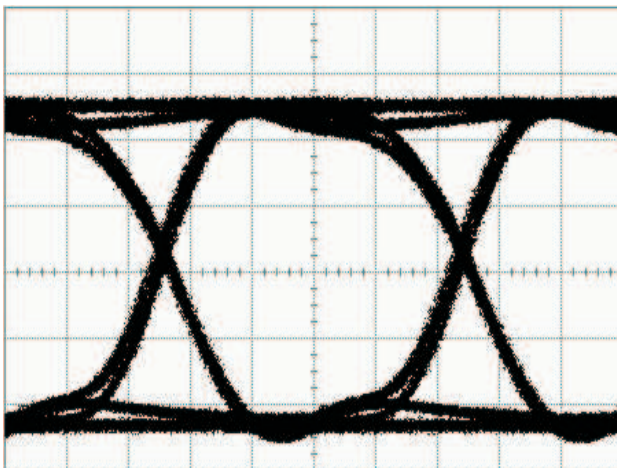

60 mV/div 20 ps/div

Figure 13.

**OUTPUT EYE-DIAGRAM AT 10.3 GBPS
AND $2\ \text{mA}_{PP}$ INPUT CURRENT**

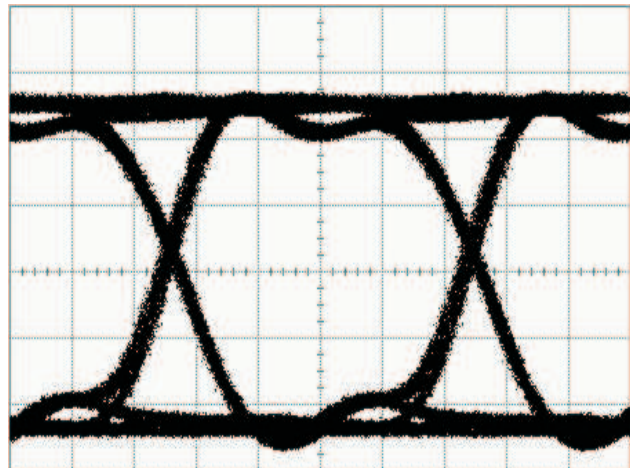

60 mV/div 20 ps/div

Figure 14.

APPLICATION INFORMATION

Figure 15 shows the ONET8521T used in a typical fiber optic receiver using the internal photodiode bias. The ONET8521T converts the electrical current generated by the PIN photodiode into a differential output voltage. The FILTER inputs provide a dc bias voltage for the PIN that is low pass filtered by the combination of an internal 220Ω resistor and a capacitor. Because the voltage drop across the 220Ω resistor is sensed and used by the bias circuit, the photodiode must be connected to the FILTER pads for the bias to function correctly.

The RSSI output is used to mirror the photodiode output current and can be connected via a resistor to GND. The voltage gain can be adjusted for the intended application by choosing the external resistor; however, for proper operation of the ONET8521T, ensure that the voltage at RSSI never exceeds $V_{CC} - 0.65V$. If the RSSI output is not used while operating with internal PD bias, it should be left open.

The OUT+ and OUT- pins are internally terminated by 50Ω pull-up resistors to VCC. The outputs must be ac coupled, for example by using $0.1\mu F$ capacitors, to the succeeding device.

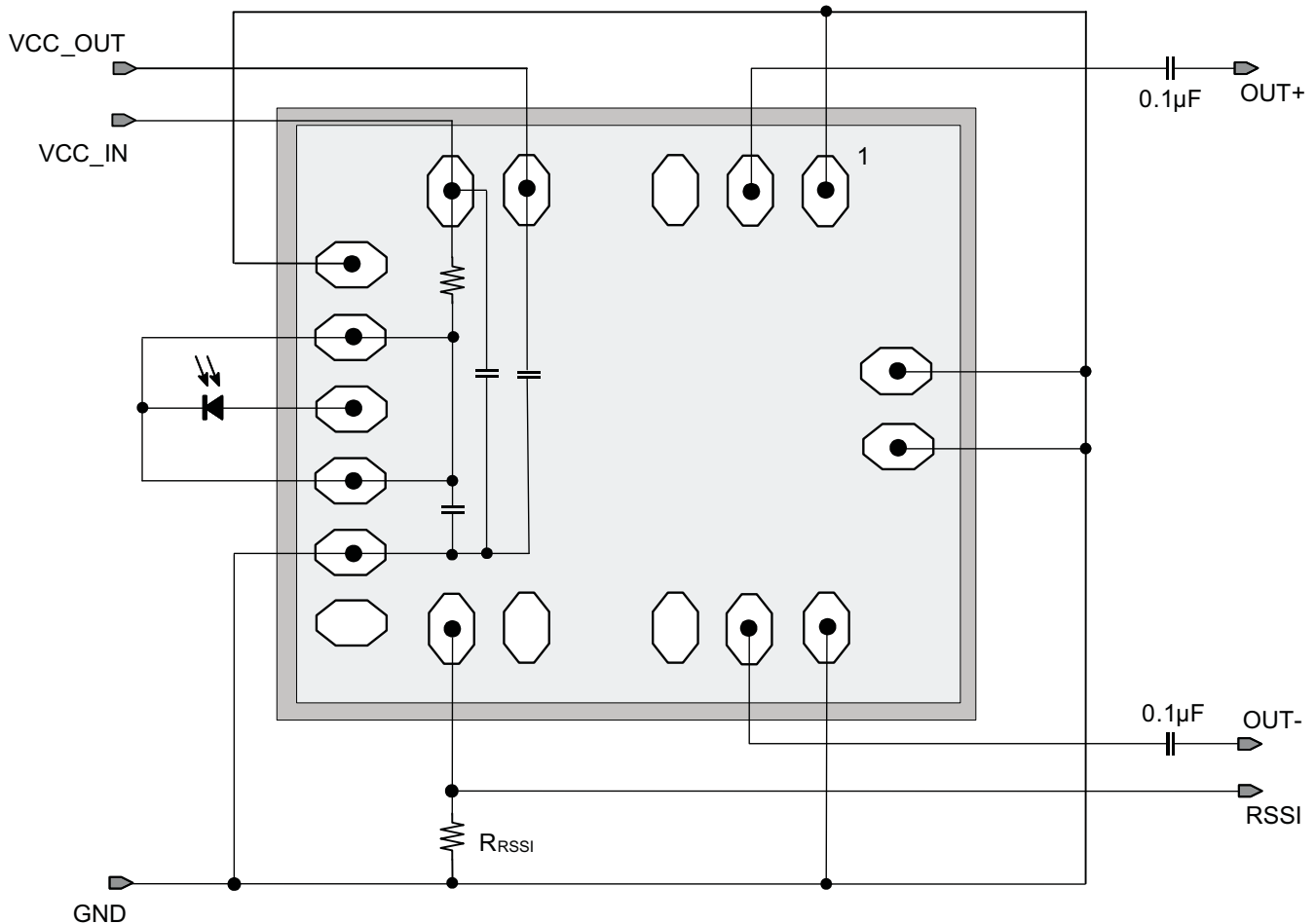

Figure 15. Basic Application Circuit for PIN Receivers

Figure 16 shows the ONET8521T being used in a typical fiber optic receiver using an external photodiode bias for an APD photodiode. This configuration can also be used for a PIN diode if desired. The external bias RSSI signal is based on a dc offset value and is not as accurate as the internal bias RSSI signal which is based upon the photodiode current.

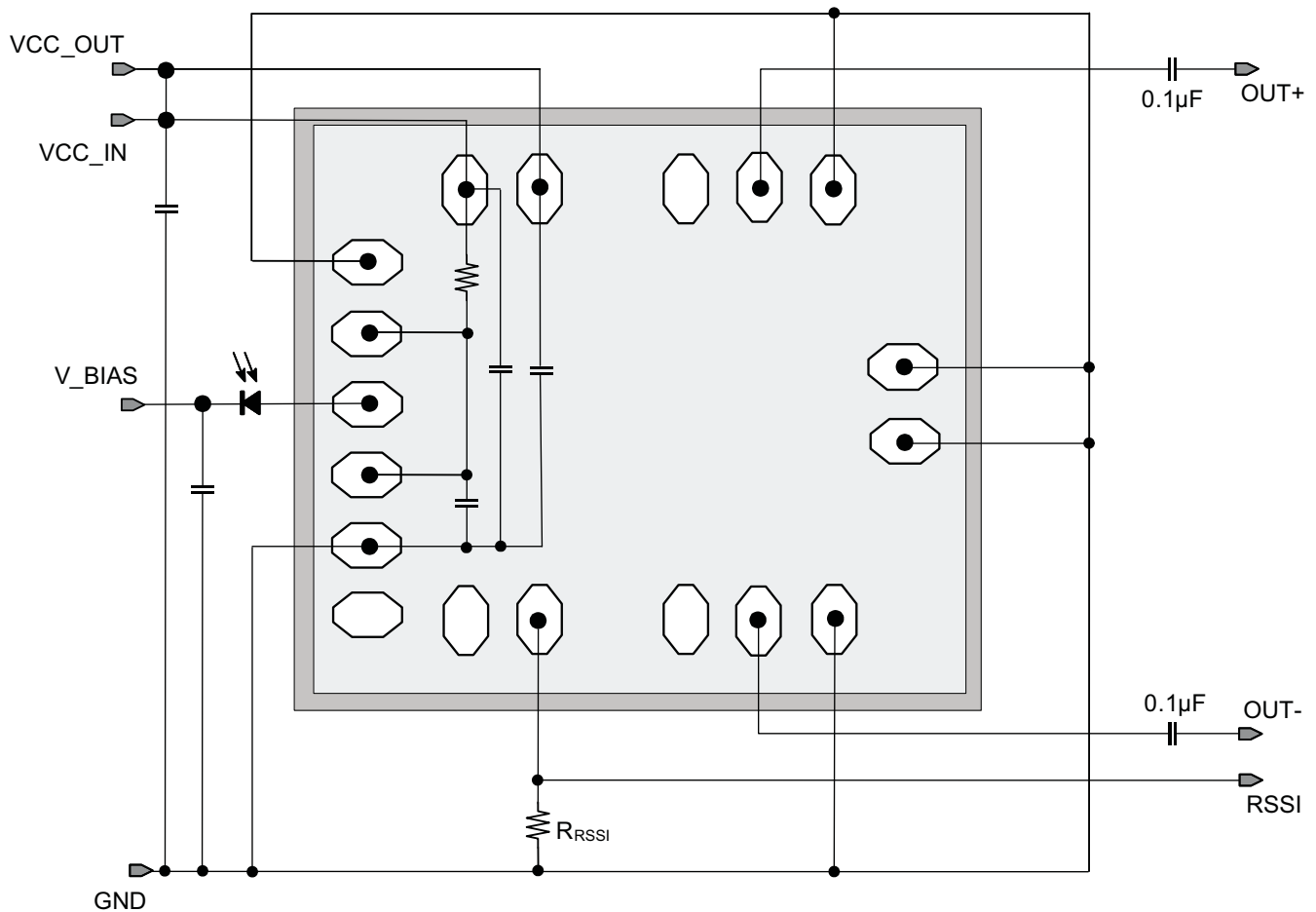

Figure 16. Basic Application Circuit for APD Receivers

ASSEMBLY RECOMMENDATIONS

Careful attention to assembly parasitics and external components is necessary to achieve optimal performance.

Recommendations that optimize performance include:

1. Minimize the total capacitance on the IN pad by using a low capacitance photodiode and paying attention to stray capacitances. Place the photodiode close to the ONET8521T die in order to minimize the bond wire length and thus the parasitic inductance.
2. Use identical termination and symmetrical transmission lines at the ac coupled differential output pins OUT+ and OUT-.
3. Use short bond wire connections for the supply terminals VCC_IN, VCC_OUT, and GND. Supply voltage filtering is provided on chip but filtering may be improved by using an additional external capacitor.

CHIP DIMENSIONS AND PAD LOCATIONS

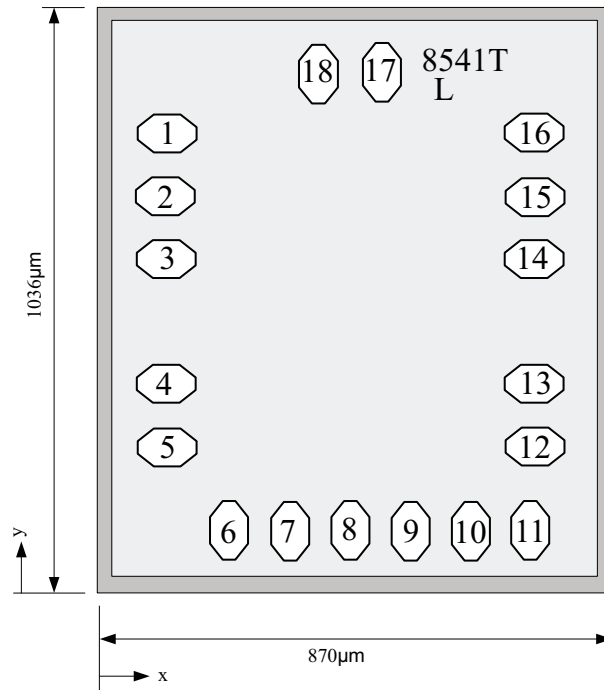

Die Thickness: 203 ± 13 µm

Pad Dimensions: 105 µm × 65 µm

Die Size: 870 ± 40 µm × 1036 ± 40 µm

| PAD | COORDINATES (referenced to pad 1) | | SYMBOL | TYPE | DESCRIPTION |
|-----|--------------------------------------|--------|---------|---------------|--|
| | x (µm) | y (µm) | | | |
| 1 | 0 | 0 | GND | Supply | Circuit ground |
| 2 | 0 | -115 | OUT+ | Analog output | Non-inverted data output |
| 3 | 0 | -230 | GND | Supply | Circuit ground |
| 4 | 0 | -460 | VCC_OUT | Supply | 3.3V supply voltage |
| 5 | 0 | -575 | VCC_IN | Supply | 3.3V supply voltage |
| 6 | 115.5 | -728 | GND | Supply | Circuit ground |
| 7 | 225.5 | -728 | FILTER1 | Analog | Bias voltage for photodiode |
| 8 | 335.5 | -728 | IN | Analog input | Data input to TIA |
| 9 | 445.5 | -728 | FILTER2 | Analog | Bias voltage for photodiode |
| 10 | 555.5 | -728 | GND | Supply | Circuit ground |
| 11 | 665.5 | -728 | NC | No connect | Do not connect |
| 12 | 671 | -575 | RSSI_IB | Analog output | RSSI output signal for internally biased receivers |
| 13 | 671 | -460 | RSSI_EB | Analog output | RSSI output signal for externally biased receivers |
| 14 | 671 | -230 | GND | Supply | Circuit ground |
| 15 | 671 | -115 | OUT- | Analog output | Inverted data output |
| 16 | 671 | 0 | GND | Supply | Circuit ground |
| 17 | 393 | 109 | GND | Supply | Circuit ground |
| 18 | 278 | 109 | GND | Supply | Circuit ground |

TO46 LAYOUT EXAMPLE

An example for a layout using an external bias voltage for the photodiode in a 5 pin TO46 can is shown in Figure 17. Figure 18 shows an example with a backside cathode contact photodiode using the internal bias voltage.

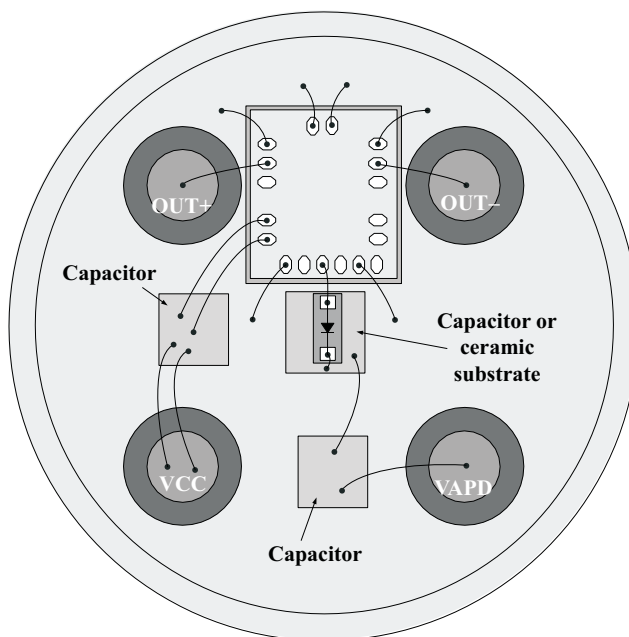

Figure 17. TO46 5 Pin Layout Using the ONET8521T with an Avalanche Photodiode

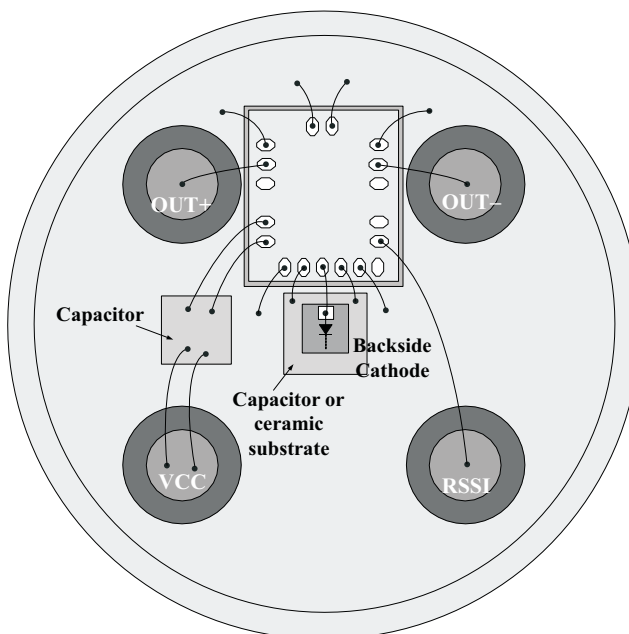

Figure 18. TO46 5 Pin Layout Using the Internal Bias Voltage for a Backside Cathode Contact Photodiode

REVISION HISTORY

| Changes from Original (July 2011) to Revision A | Page |
|---|------|
| • Changed 模具尺寸 | 1 |
| • Changed die size | 12 |

PACKAGING INFORMATION

| Orderable Device | Status (1) | Package Type | Package Drawing | Pins | Package Qty | Eco Plan (2) | Lead/Ball Finish (6) | MSL Peak Temp (3) | Op Temp (°C) | Device Marking (4/5) | Samples |
|------------------|---------------|--------------|-----------------|------|-------------|-----------------|-------------------------|----------------------|--------------|-------------------------|---------|
| ONET8521TY | ACTIVE | DIESALE | Y | 0 | 1800 | TBD | Call TI | Call TI | -40 to 100 | | Samples |

(1) The marketing status values are defined as follows:

ACTIVE: Product device recommended for new designs.

LIFEBUY: TI has announced that the device will be discontinued, and a lifetime-buy period is in effect.

NRND: Not recommended for new designs. Device is in production to support existing customers, but TI does not recommend using this part in a new design.

PREVIEW: Device has been announced but is not in production. Samples may or may not be available.

OBSOLETE: TI has discontinued the production of the device.

(2) **RoHS:** TI defines "RoHS" to mean semiconductor products that are compliant with the current EU RoHS requirements for all 10 RoHS substances, including the requirement that RoHS substance do not exceed 0.1% by weight in homogeneous materials. Where designed to be soldered at high temperatures, "RoHS" products are suitable for use in specified lead-free processes. TI may reference these types of products as "Pb-Free".

RoHS Exempt: TI defines "RoHS Exempt" to mean products that contain lead but are compliant with EU RoHS pursuant to a specific EU RoHS exemption.

Green: TI defines "Green" to mean the content of Chlorine (Cl) and Bromine (Br) based flame retardants meet JS709B low halogen requirements of <=1000ppm threshold. Antimony trioxide based flame retardants must also meet the <=1000ppm threshold requirement.

(3) MSL, Peak Temp. - The Moisture Sensitivity Level rating according to the JEDEC industry standard classifications, and peak solder temperature.

(4) There may be additional marking, which relates to the logo, the lot trace code information, or the environmental category on the device.

(5) Multiple Device Markings will be inside parentheses. Only one Device Marking contained in parentheses and separated by a "~" will appear on a device. If a line is indented then it is a continuation of the previous line and the two combined represent the entire Device Marking for that device.

(6) Lead/Ball Finish - Orderable Devices may have multiple material finish options. Finish options are separated by a vertical ruled line. Lead/Ball Finish values may wrap to two lines if the finish value exceeds the maximum column width.

Important Information and Disclaimer: The information provided on this page represents TI's knowledge and belief as of the date that it is provided. TI bases its knowledge and belief on information provided by third parties, and makes no representation or warranty as to the accuracy of such information. Efforts are underway to better integrate information from third parties. TI has taken and continues to take reasonable steps to provide representative and accurate information but may not have conducted destructive testing or chemical analysis on incoming materials and chemicals. TI and TI suppliers consider certain information to be proprietary, and thus CAS numbers and other limited information may not be available for release.

In no event shall TI's liability arising out of such information exceed the total purchase price of the TI part(s) at issue in this document sold by TI to Customer on an annual basis.

重要声明和免责声明

TI 均以“原样”提供技术性 & 可靠性数据（包括数据表）、设计资源（包括参考设计）、应用或其他设计建议、网络工具、安全信息和其他资源，不保证其中不含任何瑕疵，且不做任何明示或暗示的担保，包括但不限于对适销性、适合某特定用途或不侵犯任何第三方知识产权的暗示担保。

所述资源可供专业开发人员应用 TI 产品进行设计使用。您将对以下行为独自承担全部责任：(1) 针对您的应用选择合适的 TI 产品；(2) 设计、验证并测试您的应用；(3) 确保您的应用满足相应标准以及任何其他安全、安保或其他要求。所述资源如有变更，恕不另行通知。TI 对您使用所述资源的授权仅限于开发资源所涉及 TI 产品的相关应用。除此之外不得复制或展示所述资源，也不提供其它 TI 或任何第三方的知识产权授权许可。如因使用所述资源而产生任何索赔、赔偿、成本、损失及债务等，TI 对此概不负责，并且您须赔偿由此对 TI 及其代表造成的损害。

TI 所提供产品均受 TI 的销售条款 (<http://www.ti.com.cn/zh-cn/legal/termsofsale.html>) 以及 [ti.com.cn](http://www.ti.com.cn) 上或随附 TI 产品提供的其他可适用条款的约束。TI 提供所述资源并不扩展或以其他方式更改 TI 针对 TI 产品所发布的可适用的担保范围或担保免责声明。

邮寄地址：上海市浦东新区世纪大道 1568 号中建大厦 32 楼，邮政编码：200122
Copyright © 2019 德州仪器半导体技术（上海）有限公司